

**PATH TO NEARLY-ZERO ENERGY &
CLIMATE NEUTRAL-BUILDINGS
(IN EUROPE)**



FIRST Q NETWORK | BUILDING PHYSICS GROUP

2021

“

The global building stock will double in area by 2060 with the addition of 230 billion square meters of new floor area, equivalent to adding another New York City to the planet every 34 days.





FIRST Q WHITE PAPER SERIES

FOREWORD

In 2019 the world's leading scientists declared, clearly and unequivocally that planet Earth is facing a climate emergency. This followed the 2018 report by the Intergovernmental Panel on Climate Change (IPCC) which stated that to keep the rise in global temperatures below 1.5°C this century, emissions of carbon dioxide would have to be cut by 45% by 2030. Worldwide, buildings generate nearly 40% of global greenhouse gas emission.

According to Architecture 2030, global building stock will double in area by 2060 with the addition of 230 billion square meters of new floor area, equivalent to adding another New York City to the planet every 34 days.

Yet, buildings also offer the greatest potential for achieving significant GHG emission reductions, at least in developed and developing countries. Furthermore, energy consumption in buildings can be reduced by 30 to 80% using proven and commercially available technologies.

The EU's Energy Performance of Buildings Directive (EPDB) is the mechanism by which significant operational energy reductions will be achieved over the coming years. Successful implementation of the EPBD will play a crucial role for First Q member firms during this decisive 'decade of action', now widely accepted as our last chance to avoid the worst effects of irreversible climate change. The journey to climate neutral buildings will vary from country to country. However, all First Q members are engaged in this movement towards the goal of nearly zero energy or climate neutral buildings (nZEB).

Global CO2 Emissions by Sector

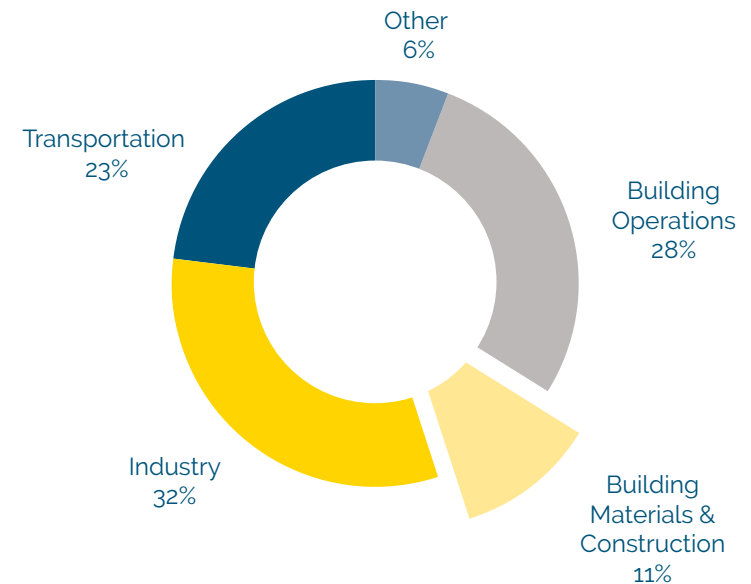

Source: Global Alliance for Buildings and

ABSTRACT

This paper aims to evaluate the implementation of the nearly Zero-Energy-Building (nZEB), introduced by Energy Performance of Building Directive (EPBD), in the building energy standards of EU state members as well as building projects of the members of First Q network. Through brief introduction of the regulations and requirements of nZEB and climate neutral building in different countries and considering their sample projects which fulfil these requirements in each country, it will be possible to find out the deviations between regulations and determine common KPIs for primary energy demand, end energy demand and CO₂-Emission of the buildings within the nZEB platform among all cases; The outcome of this work will demonstrate a clear image of the improvements made by implementing different active and passive measures in the buildings planned by FirstQ members and will lead us towards practical recommendations to accelerate our movement through nZEB and climate neutral building.

Keywords: nearly Zero Energy Buildings, Energy Performance of Building Directive, Climate Neutral Buildings, Renewable Energies, Building physics, Primary Energy Demand, End Energy Demand, Energy Efficiency, FirstQ, CO₂ Emissions

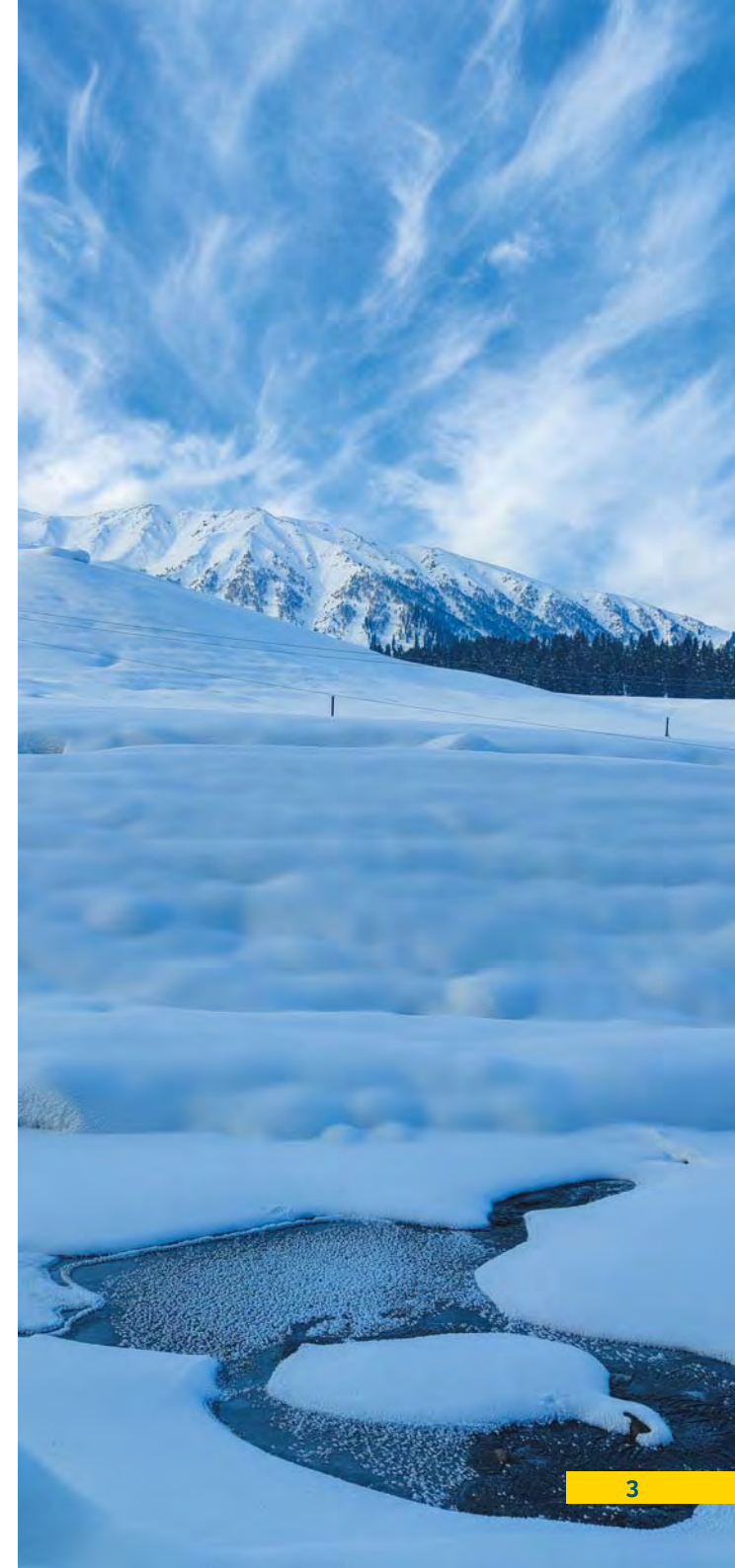

ACKNOWLEDGMENTS

The completion of this paper would not have been possible without the valuable inputs and contributions of the First Q members which listed in alphabetical order as follows:

Belgium: Ingenium NV (Raf De Herdt, Pedro Pattijn, Nico De Roeck)

Finland: Granlund Group (Pekka Metsi)

France: Barbanel (Florian Pingaud)

Germany: ZWP Ingenieur-AG (Alfred Wallau, Nedim Hodzic, Hamidreza Esfehiani)

Ireland: Ethos Engineering (Michael Boyle, Abdulhamid Alrehaili, PJ Ryan)

Italy: Manens-Tifs s.p.a. (Andrea Fornasiero)

Lithuania: MEPCO JSC (Gediminas Šilanskas)

Portugal: LMSA-Engenharia de Edifícios (Luis Malheiro, Hugo Guerreiro, Rui Carreiro)

Spain: JG Ingenieros S.A (Eduardo Theirs, Albert Artús)

Sweden: Bengt Dahlgren Göteborg AB (Jennie Ekbohm, Giovana Fantin Do Amaral Silva)

Switzerland: Waldhauser + Hermann AG (Martin Imhof-Müller)

CONTENTS

07

INTRODUCTION

07

BACKGROUND

08

REFERENCE
CLIMATE
REGIONS

10

EUROPEAN
FRAMEWORK

13

BELGIUM

21

FINLAND

29

FRANCE

40

GERMANY

46

IRELAND

55

ITALY

65

LITHUANIA

72

PORTUGAL

80

SPAIN

86

SWEDEN

92

SWITZERLAND

96

SUMMARY

96

OVERVIEW

100

CONCLUSION
AND OUTLOOK

102

LIST OF
ABBREVIATIONS

102

LIST OF TABLES

103

LIST OF FIGURES

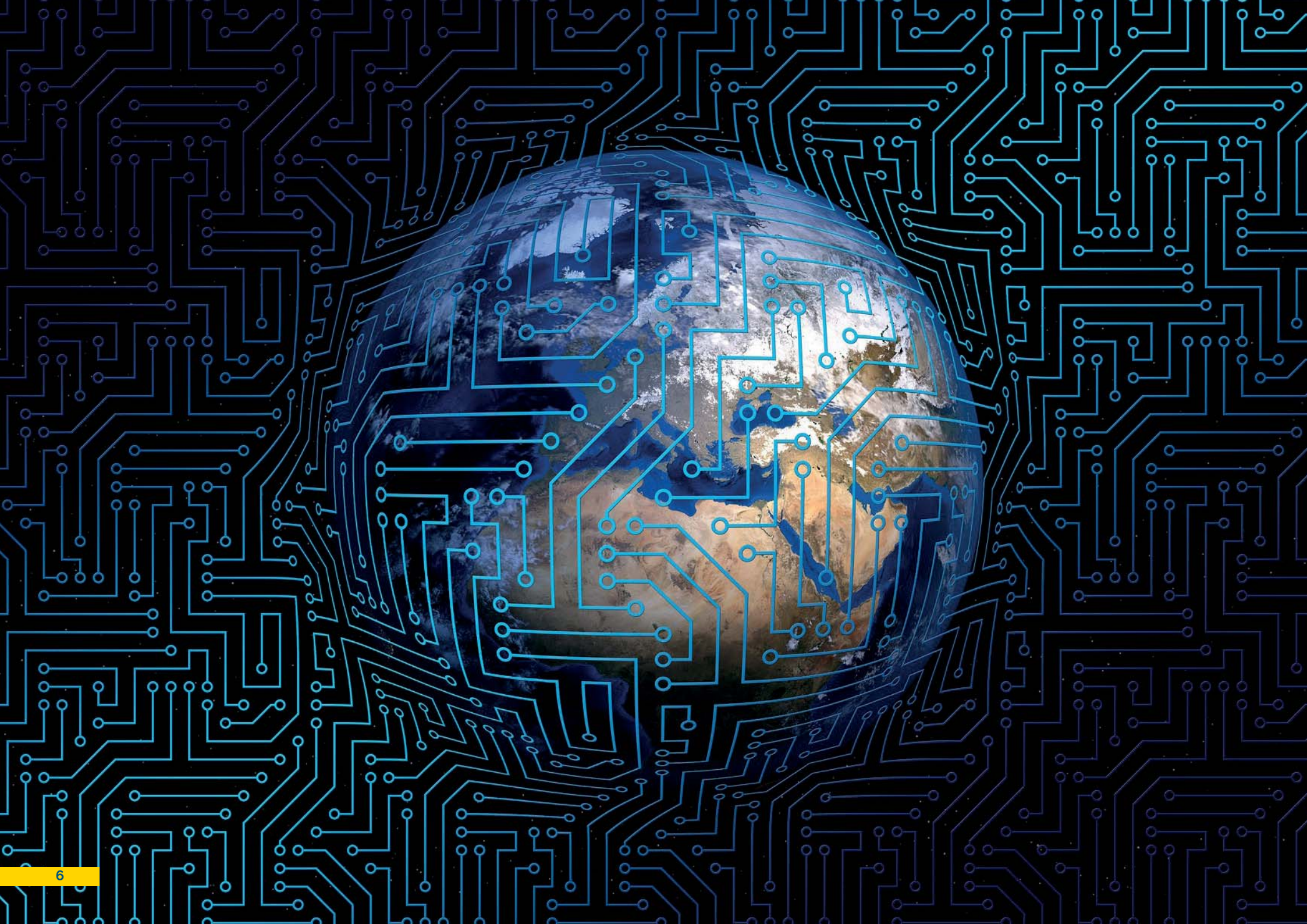

INTRODUCTION

BACKGROUND

The aim of Building Physics is to provide a comfortable and pleasant interior that is defined as a space with good thermal (temperature & humidity), acoustical (room acoustics & noise protection) and lighting (artificial lighting & daylight) conditions through technically efficient solutions. Above mentioned requirements should be achieved with sustainable and Eco-friendly building concepts and supply systems that will lead us to tackle the climate-neutral targets in the building sector.

The FirstQ Network, as Europe-wide network of engineering companies and design consultants, focuses on the comfort demands of the building users; The FirstQ efforts are oriented to fulfil these demands through most energy efficient and sustainable ways. Our economies need to become climate-neutral within the foreseeable future (by 2050). Concrete objectives in this regard have been defined internationally. New buildings erected today normally have useful lifetimes of 50 years and longer. In existing buildings, the new standards must be implemented, in the framework of energy-oriented modernizations, by 2050 at the latest.

Our energy design services, provided by our multi-disciplinary team of specialists, addresses these challenges. We have a passion for construction-sector progress in the areas of climate-neutrality, resources conservation and sustainability. At the same time, we never forget that buildings need to serve their occupants. They need to provide comfortable spaces for living and working, and they need to be cost-effective in operation. These different basic criteria define the framework for our energy concepts, which we develop and verify with the help of dynamic building and system simulations and implement with the help of our extensive experience. In keeping with our aim to serve a diverse range of clients, including building owners, architects and building users, we take a multi-disciplinary approach.

REFERENCE CLIMATE REGIONS

Europe has a wide spectrum of climates, ranging from polar tundra in the far north and northeast to desert regions in the southwest. Understandably, standards for buildings vary accordingly to fit the given geopolitical conditions. Some regions need to rely on insulation, other on thermal storage, some need to keep both in mind. Some buildings can get a significant portion of energy through renewable resources on site, others must rely on passive measures only. The challenges involving a design of nZEBs are tightly related to the specific place of construction and several other factors. There is no one formula for the design of such buildings. Energy efficiency in both the building fabric and MEP systems is the golden thread which links all nZEB buildings.



Figure 1: Map of the Köppen-Geiger climate classification
 [Source: <http://www.koeppen-geiger.vu-wien.ac.at>]

EUROPEAN FRAMEWORK

According to article 2 of Energy Performance of Building Directive (EPBD), the European Union has introduced “nearly Zero Energy Buildings” (nZEB) as a standard by 2020. Since last year, the entire member states have been committed to observe this standard in their public buildings and from 2021, all new buildings must fulfil the requirements of nZEB standard. Interim targets are:

Reduction in the heat requirement of the building stock by 20% by 2050

Reduction in the primary energy requirement by 80% by 2050

Aim of achieving an almost climate-neutral building stock by 2050

Based on EPBD, nZEB is a building with a very high-energy performance that has a significant share of renewable sources, including on-site or nearby sources, in energy supply. The Energy Performance of the building is expressed as the building overall primary energy demand which refers to the entire building energy services to the conditioned area. Due to the fact that the countries are located in different climate zones that results in different heating and cooling requirements in the buildings, EPBD did not set any numeric threshold or requirement for nZEBs and allowed scope for the Member States to develop their own measures and regulations for nZEB. However, using different calculation methodologies as well as setting different key performance indicators (KPI) for assessment of the energy performance in the building results in significant different interpretations of nZEB between countries, making implantation of the EPBD challenging. This highlights the high necessity of finding a common denominator to identify nZEB at national levels as well as EU level.

Determining the amount of primary energy demand, end energy demand and renewable energy share of a building is strongly dependent on the energy balance and system boundaries for a building; Possible system boundaries for a building are illustrated in Figure 2, as it is seen considering on-site, nearby or off-site energy sources results in different energy balance for a building.

In the building energy balance in Equation (1), the amount of delivered energy to the building ($E_{del,i}$) as well as the exported energy from the building ($E_{exp,i}$) are correlated with the boundaries of the system, furthermore the primary energy factors ($f_{p,del,i}$ and $f_{p,exp,i}$) of the energy carriers used in the building is also a deciding parameter in calculating energy demand of the building.

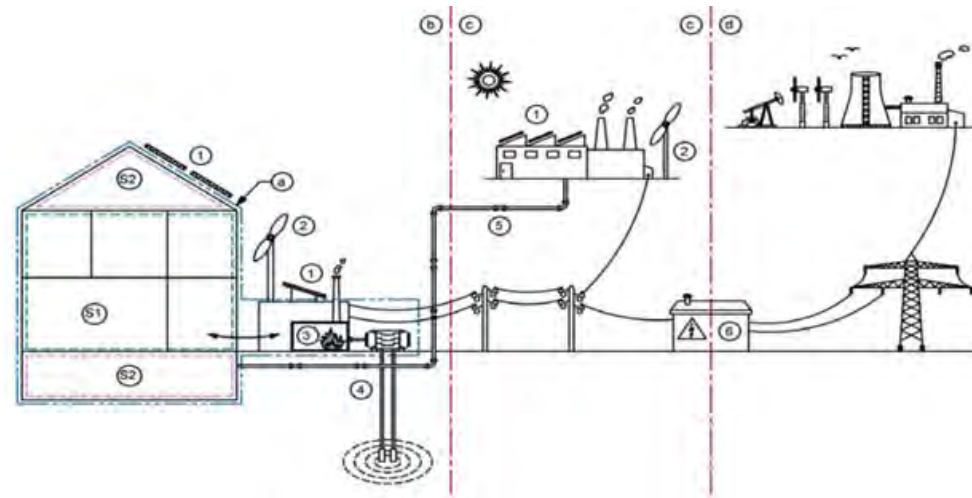

Figure 2: Possible system boundaries for a building [Source: EN ISO 52000-1: 2017]

$$E_P = \sum(E_{del,i} \times f_{P,del,i}) - \sum(E_{exp,i} \times f_{P,exp,i}) \quad (1)$$

Another important parameter that has been less focused in the assessment of the building performance is CO2 emission of the building. Developing the CO2 balance for the net energy use of the building is one of the KPIs that can be applied as strong alternative to primary energy demand and can represent a clear and practical criterion for the sustainability of the energy supply systems in the building which accelerates the movement through "CO2-free buildings in 2050" set by EU as the objective for building sector.

BELGIUM



REGULATIONS AND FIRST Q BEST PRACTICE

FIRST Q NETWORK | BUILDING PHYSICS GROUP

REGULATIONS AND FIRSTQ BEST PRACTICE

BELGIUM

COUNTRY REGULATION

The energy performance of buildings in Belgium differs from region to region. The basic steps (calculation of the energy needed and used) and minimum requirements of the building physics are mostly the same in the 3 regions, but the indicator of the primary energy index differs, therefore also the requirements for nZEB.

The requirements and calculations depend on the building category. If parts of a mixed-use building belong to different categories, the building is split up into different volumes with its own requirements. The resulting building indicator is the average by usable floor area of the different categories.

All three regions (Flemish, Walloon and Brussels capital region) incorporate the energy use of space heating, cooling domestic hot water and auxiliary devices of these systems when calculating the primary energy use of residential buildings. When calculating the energy performance of non-residential buildings like office buildings, the energy of lighting is also considered. The inclusion of energy use of DHW depends on the region.

The Flemish region uses the primary energy indicator "E", which is the ratio of the primary energy consumption of the building to that of a reference building, to indicate the energy performance of a building. nZEB-buildings are defined as a "BEN"-building, which stands for "Bijna EnergieNeutraal" or "Almost Energy Neutral".

Corresponding E-levels are:

Table 1: nZEB Levels Flemish Region

Category	nZEB E-level
Residential	E30
School	E55
Office	E50
Other	E40 – E80

The same primary energy indicator “E” is used in the Walloon area, which is the ratio of the primary energy consumption of the building to that of a reference building, to indicate the energy performance of a building. The nZEB-levels differ from the Flemish region.



Figure 3: BEN-label Flemish region

Table 2: nZEB Level Walloon region

Category	nZEB E-level
Residential	E45
School	E45
Office	E45
Other	E90

The Brussels primary energy index, PEV, is used. Which is the specific primary energy use of the building (kWh/m²·year). There is no fixed maximum PEV defined for a building to be nZEB, it depends on the compactness and volume for residential buildings and on the different functions in the building and a reference primary energy consumption for non-residential buildings.

Table 3: nZEB Level Brussels

Category	nZEB PEV-level
Residential	45*(parameters relating to compactness and volume) kWh/m ² ·year
School	0,45 * PEV _{reference}
Office	0,45 * PEV _{reference}
Other	0,45-0,80 * PEV _{reference}

SAMPLE PROJECT

The extension to the office building of Stadsbader (ca. 2.600 m²) is the continuation of the master plan on the site and will house the ever-growing support services. In collaboration with the architect of Bureau DGB, Ingenium did the engineering of the technical installations of this project and acted as a sustainability consultant including the assessment of the Flemish building regulations. The goal for the design team was to build a nearly Zero Energy Building, taking Total Cost of Ownership in mind.

The first and obvious step in designing this nZEB was optimizing the building physics with dynamic simulation. The goal was finding an optimum between cooling and heating demand in respect to thermal comfort in the building. Different scenarios were simulated and compared to a reference case. Following building parameters have been optimized:

- Window to wall ratio
- Glazing type (SHG-value)
- Degree of insulation
- Different types of solar shading



Figure 4: Stadsbader office building

Table 3 shows the results of the parameter optimisation.

Table 3: Building Physics

Element	Value
Window/Wall	30%
U_{Window}	0,95 W/m ² K (total U-Value of glass and frame)
$SHGC_{Window}$	0,5
Solar shading	Orientation E/S/W – SHGC 0,036 – Automaticly controlled
U_{Wall}	0,17 W/m ² K
U_{Roof}	0,10 W/m ² K
U_{Floor}	0,24 W/m ² K

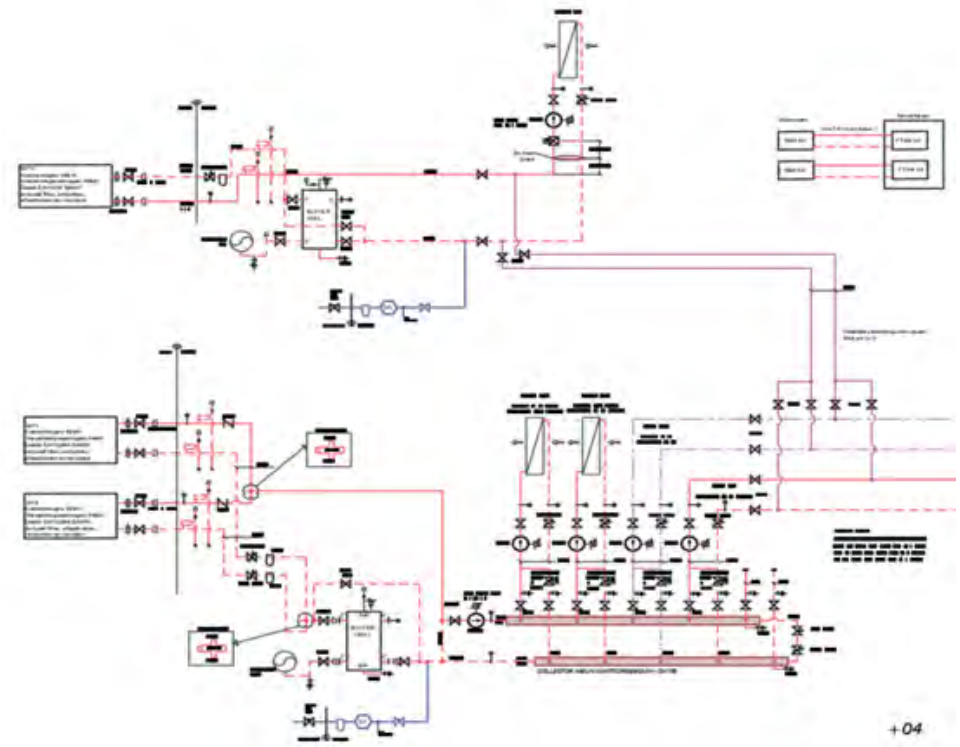

Figure 5: Hydraulic scheme heating and cooling

The next step in the design was the choice of the HVAC-system. Since comfort was an important issue, thermally activated floors (TABS) are used in the project to deliver the baseload for heating and cooling, supplemented with heating and cooling of the hygienic ventilation. The air handling units are equipped with rotative heat recovery with very high thermal and hygroscopic efficiency to reduce the loads. Required heating and cooling is delivered by 3 air to water heat pumps.

Further optimization of the energy demand of the building existed in the optimization of the electricity demand. Air ducts and air handling units are designed to limit the pressure drop and therefore the fan consumption. LED lighting is provided with detection of presence and daylight control. A photovoltaic system of 30 kW is installed to cover the baseload of the electricity demand.

These technical features together with the excellent building envelope ensure that this building achieves the BEN label in Flanders. The primary energy use indicator of the building is E40, which is significantly lower than the requirements for nZEB in Flanders (E50).



Figure 6: Energy performance certificate

FINLAND



REGULATIONS AND FIRST Q BEST PRACTICE

FIRST Q NETWORK | BUILDING PHYSICS GROUP

FINLAND

COUNTRY REGULATION

Police in general

In Finland, energy performance regulation was introduced by the Ministry of Environment since 1976, as part of the National building code, which have been tightened 4 times with additional 30% of improvement targets in each revision, and over 30 policy instruments were complemented for energy use in buildings (Figure 7 below shows the mix of Finnish policy research in 2017). In 2018, the new revision of the national building code was set in part due to the implementing the EPBD, new buildings occupied and owned by public authorities from 2019 were required to be nearly zero energy buildings, and all new buildings after 2021 are mandatory to meet nearly zero energy buildings standard.

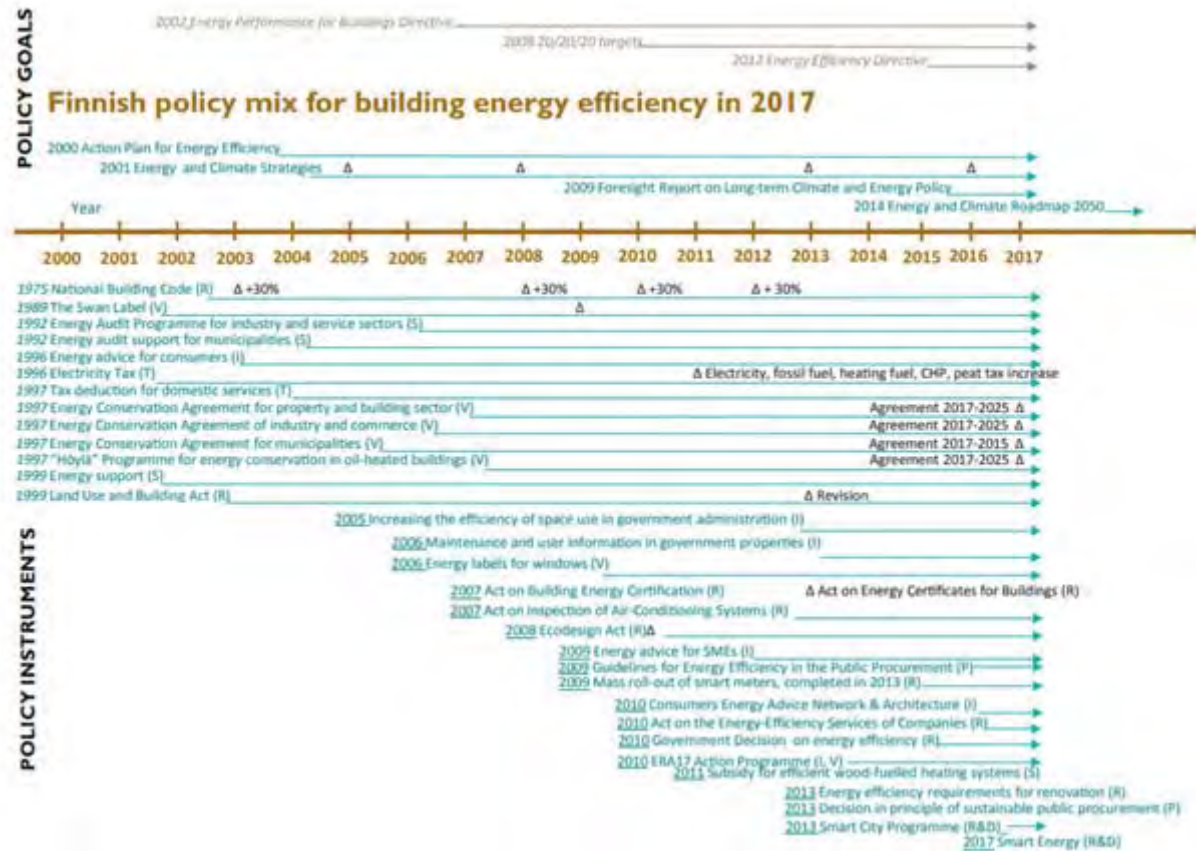

Figure 7: Finnish policy mix for building energy efficiency in 2017

Building code implementation for new buildings

All new buildings are required to have Energy Performance Certificate when applying building permit, which demonstrates the energy rating as shown in the sample certificate (Figure 8). Currently all buildings are targeted to meet at least Class B requirement.

The energy rate is given as E-value (kWh_E/m^2), which uses the calculated annual consumption of delivered energy weighted by energy carrier factors (Table 5) per the building's net heated area. The National Building Code of 2017 sets the minimum value depending on the building type (Table 4), each building type has the normative usage profile and standard internal loads including domestic hot water demand.

Distinct from whole building energy rating, National Building Code also provides minimum requirement for thermal insulation, technical system performance and indoor environment. For example, in all buildings air handling unit heat recovery efficiency should be above 68 %, indoor operative temperature should meet 90 % stability, etc.

The image shows a sample Finnish Building Energy Certificate 2018. The certificate is titled "ENERGY CERTIFICATE 2018" and contains the following fields and information:

- Name and address of building:** (Empty field)
- Permanent building code:** (Empty field)
- Completion year of building:** (Empty field)
- Use category of building:** (Empty field)
- Certificate code:** (Empty field)
- The energy certificate is drawn up for:**
 - New building when applying for the building permit
 - New building when taking the building into use
 - Existing building, the date of observation visit
- Energy performance class:** A scale from A (green) to G (red) is shown. The current class is C, indicated by a black arrow pointing to the C level.
- The calculated energy performance reference value of the building, i.e., the E value:** (Empty field) $\text{kWh}_E / (\text{m}^2 \cdot \text{year})$
- The requirement for the E value of a new building:** (Empty field) $\text{kWh}_E / (\text{m}^2 \cdot \text{year})$
- Certificate produced by:** (Empty field)
- Company:** (Empty field)
- Electrical signature:** (Empty field)
- Date of production:** (Empty field)
- Last day in force:** (Empty field)

Figure 8: Example of Finnish Building Energy Certificate

Table 4: Primary energy consumption (E-value) limit for different building types

Intended use category	Limit for E-value kWh _E /(m ² ·year)
Category 1)	
Small residential buildings:	
a) Detached houses and link-detached houses with a net heated area (A _{net}) of 50 – 150 m ²	200 – 0,6 A _{net}
b) Detached houses and link-detached houses with a net heated area (A _{net}) exceeding 150 but not exceeding 600 m ²	116 – 0,04 A _{net}
c) Detached houses and link-detached houses with a net heated area exceeding 600 m ²	92
d) Terraced houses and blocks of flats with residential storeys on a maximum of two storeys	105
Category 2)	
Blocks of flats with residential storeys on at least three storeys	90
Category 3)	
Office buildings, health centres	100
Category 4)	
Commercial buildings, department stores, shopping centres; wholesale and retail trade buildings, excluding grocery trade units under 2,000 m ² ; shopping halls, theatres, opera, concert and congress halls, cinemas, libraries, archives, museums, art galleries, exhibition halls	135
Category 5)	
Accommodation establishment buildings, hotels, boarding houses, assisted living accommodation, retirement homes, residential care institutions	160
Category 6)	
Education and training buildings and day-care centres	100
Category 7)	
Buildings for sports and physical exercise, excluding indoor swimming pools and indoor ice rinks	100
Category 8)	
Hospitals	320
Category 9)	
Other buildings, warehouses, transport and communications buildings, indoor swimming pools, indoor ice rinks, grocery trade units under 2.000 m ² , portable buildings	no limit

Table 5: Primary energy factors

	Weighting factor for energy source in the new building code of 2017
Fossil fuels	1.0
Electricity	1.2
District heating	0.5
District cooling	0.28
Renewable fuels	0.5

Due to the cold climate, buildings in Finland had long adopted very high energy efficiency construction, for example, windows U value limit is 1,0 W/m²K, building envelope infiltration q₅₀=4 m³/hm². To pass the Nearly Zero Energy Building requirement, the new building code encourages the use of district energy solutions and renewable energy (e.g. solar heating and power). In recent years heat pump installation has already progressed at a rapid pace. In addition, integration of deep ground boreholes has started in a few commercial projects.

Building code implementation for refurbishments

In 2013, the energy performance regulations issued energy saving requirement for existing buildings undergoing renovation and retrofitting. The requirements outline 3 options (summarized in Figure 9) in the planning phase, to ensure old building's upgrading work achieving good overall energy savings. The Finnish government have introduced various financial incentives and tax discounts to support renovation projects with adoption of renewable energy. This contributes to a substantial reduction of the overall energy use in buildings in Finland.

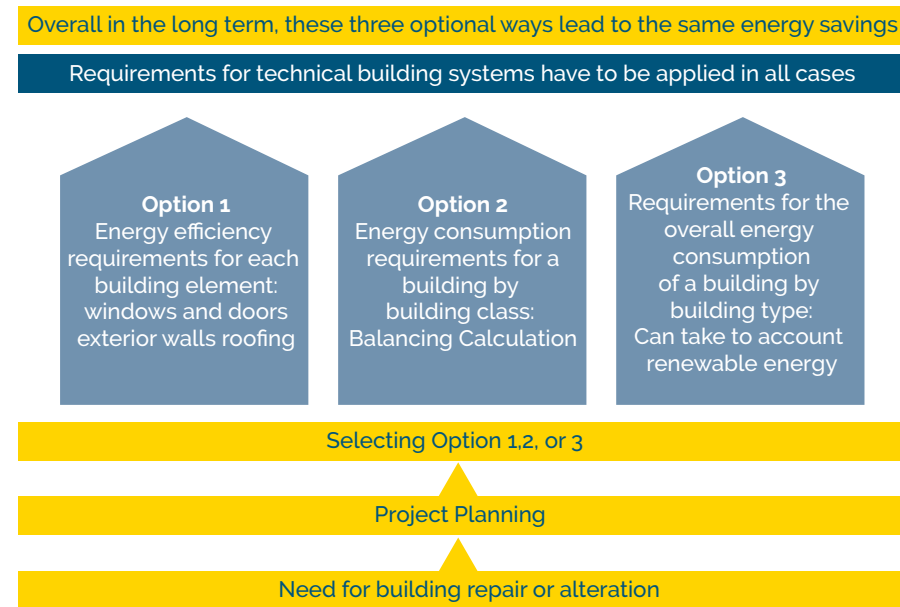

Figure 9: Energy performance requirements for building renovation

SAMPLE PROJECT

Tripla is a large development project in central Pasila in Helsinki, it is a three-block complex (Figure 10) including a shopping centre, apartments, hotel, offices and multi-purpose arena, which also connects to a main public transport terminal. Granlund Oy was appointed as the main HVAC, electrical designer and energy consultant since the beginning of the project planning phase. This is one of the first commercial buildings designed to demonstrate Finnish Nearly Zero Energy Building principle. The Mall of Tripla was awarded the LEED platinum certification upon completion.

In the development process, Granlund Oy studied the following options:

- Connection to Helsinki city district heating and cooling network
- Good control of air tightness
- Windows with U value of 0.7 W/m²K and g value of 30 %
- LED lighting with smart controls are used to minimize light electricity consumption
- Green roof covers 40 % of exterior roof
- Air handling units with high heat recovery efficiency 78 %
- Demand controlled ventilation
- High efficiency fans with reduced fan power consumption



Figure 10: Photo of Tripla
[Source: <https://www.yit.fi/en/homes/apartments-for-sale/helsinki/pasila/tripla>]

At the time of applying for a building permit in 2016, Nearly Zero Energy Building guideline was just released as draft, the E-value target for commercial building was set to 101 kWh_E/m², the final submission for Tripla presented the E-value of 80 kWh_E/m² for the shopping mall and 95 kWh_E/m² for the commercial area in the station. These E-values would also fulfil the current Finnish Nearly Zero Energy Building classification.

Figure 11 shows the detail energy breakdown for these two areas in Tripla.

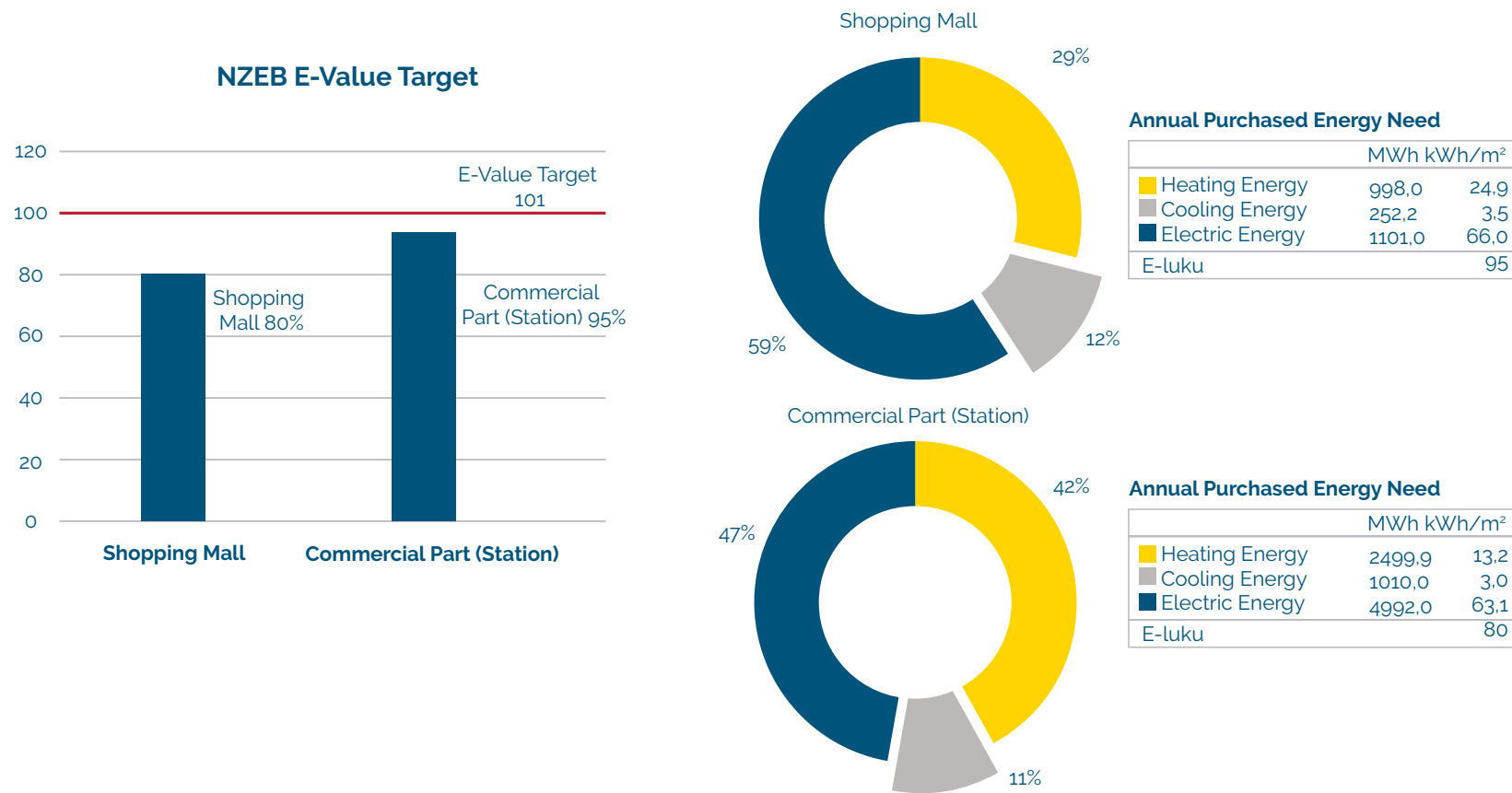

Figure 11: Calculated energy consumptions

FRANCE



REGULATIONS AND FIRST Q BEST PRACTICE

FIRST Q NETWORK | BUILDING PHYSICS GROUP

FRANCE

COUNTRY REGULATION

First Regulations

The first French Thermal Regulation was edited for new dwellings in 1974 following the first Oil Crisis. It introduced an obligation to install insulation and heating control systems. The level of requirement was strengthened in 1982. In 1988 an obligation of means was introduced towards the building envelope and HVAC systems, and this regulation also incorporated non-residential buildings.

RT 2000 & RT 2005

The emergence of Sustainable Development and the will to reduce Green House Effect, embodied by the Rio Summit in 1992 and the Kyoto Protocol in 1997, led France to go a step further in reducing energy consumption and carbon emissions of buildings. The Thermal Regulation 2000 (RT 2000) was developed for new constructions, introducing an obligation of results regarding energy consumption, while keeping obligations of means. It consisted in comparing the primary energy consumption of the project through a dynamic thermal simulation, with a baseline building of which characteristics were set up by statutory guidance. It also introduced a thermal comfort indicator called Internal Conventional Temperature (Tic).

The next regulation RT 2005 kept the previous regulation's basics, while being more stringent. The mandatory thermal simulation covered up energy consumption for HVAC, hot water, lighting, and auxiliary systems. It did not take into account specific tenant use such as process equipment, computers or domestic equipment, as the goal of the regulation was to assess the building performance itself. The RT 2005 also introduced several energy labels for efficient buildings that went far beyond the requirements.

Meanwhile a regulation for existing buildings was elaborated in 2008, based on the same calculation method as the RT2005, with specific obligation of means on building envelop and systems. It is still mandatory by now.

RT 2012

The "Grenelle de l'Environnement" in 2007 pushed forward a National Strategy to reduce energy and carbon, keeping the construction industry as the centre of this Strategy. Significant changes were undergone for the new regulation RT 2012. Above all, the new regulation greatly reinforces the requirements, putting previous RT 2005 high performance labels as the new standards. It introduced a new indicator about the bioclimatic need called Bbio. Construction projects have to show compliance with the following key indicators:

- **Bbio:** Bioclimatic performance
- **Cep:** Conventional energy consumption, in primary energy. It includes HVAC, hot water, lighting, auxiliary systems.
- **Tic:** Internal conventional temperature.

The RT 2012 sets aside the concept of comparing the new construction to a baseline building. Instead, the new regulation sets a fixed threshold for the previous key indicators, which depends only on the use of the building, the climatic zone and altitude. For instance, energy consumption of residential buildings shall be kept below 40 to 65 kWh_{ep}/m²·year, and office buildings below 110 to 132 kWh_{ep}/m²·year.

One of the main aspects of the RT 2012 lies in its complexity, as a new method has been specifically developed. While it still consists in a dynamic thermal simulation, the mandatory calculation method is now running over 1500 pages, making RT 2012 an exceedingly complex regulation.

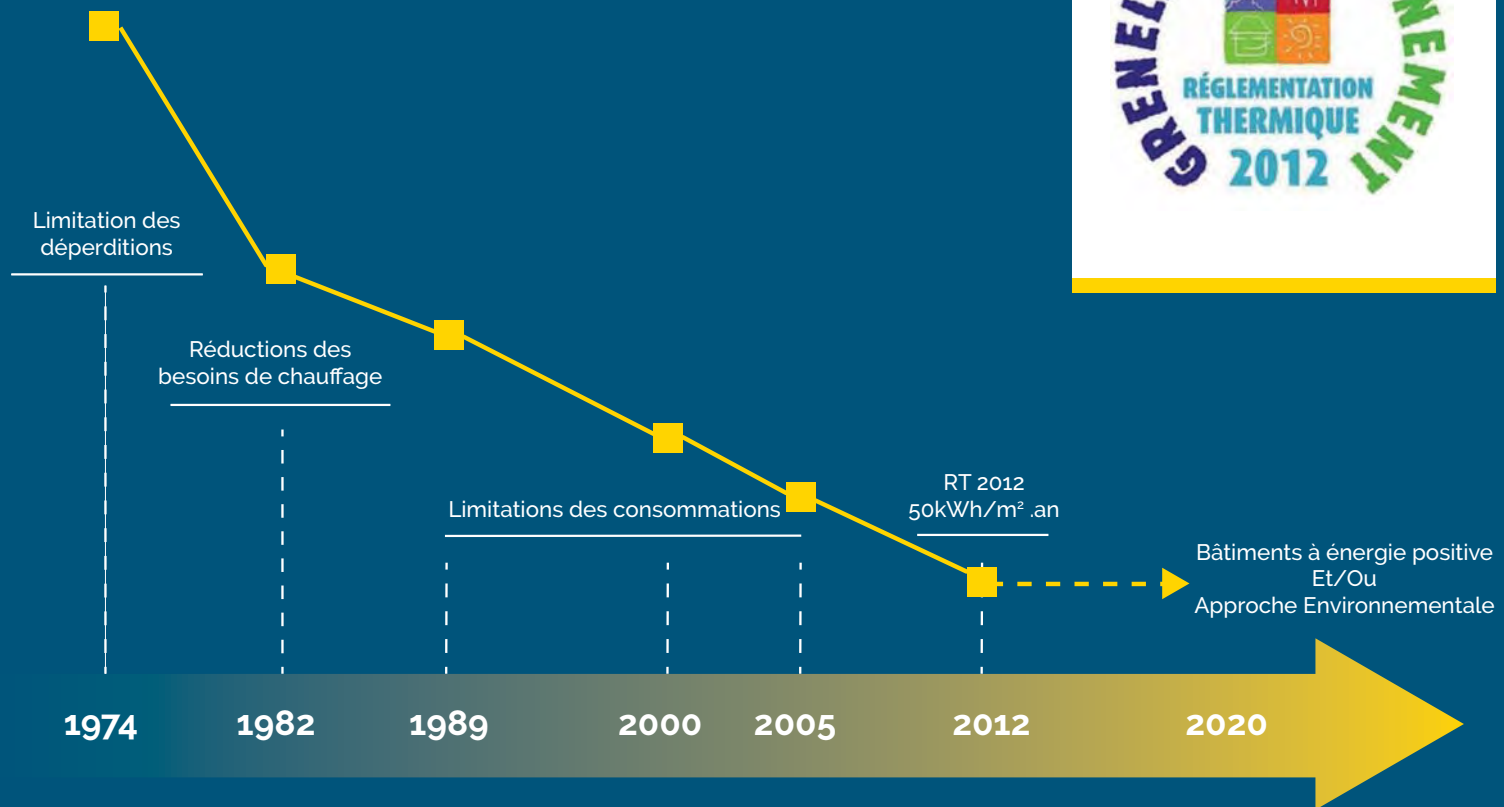

Figure 12: Limit of maximum energy consumption of new residential buildings

RE 2020

Starting from the 1st of January 2022, RT 2012 will be gradually replaced by a new regulation, the highly anticipated Environmental Regulation 2020 (RE 2020). This regulation constitutes a major change in the French low-carbon strategy as it introduces a requirement on embodied and operational Carbon through a life cycle analysis, in addition to the previous criteria.

Building such a regulation is a very complex task to achieve, especially as it will apply to any new constructions on the whole French territory. This implies major changes and has an impact on construction cost. The process of elaborating this regulation started in 2016 with the E+C- experimentation, which was developed to assess the technical and economic feasibility of the performance levels (4 levels for energy, 2 for carbon), and to help the stakeholders anticipate the new regulation.

To proceed smoothly the RE 2020 has been split into 3 phases at least. The first phase will only concern residential units. The regulation documents should be published and passed this summer and shall apply by 1st January 2022. The next step should follow during the next months and will incorporate office and educational buildings. The last phase should include the rest of tertiary buildings (retail, hotels, restaurants, health facilities, warehouses, etc.) but it will not come out soon as all the efforts are currently put into publishing the texts for residential, office and educational facilities.

Compliance to RE 2020 will be met if the results are under fixed thresholds for the following indicators:

- **Bbio:** Bioclimatic performance
- **Cep nr:** Non-renewable conventional energy consumption, in primary energy.
- **Cep:** Conventional energy consumption, in primary energy.
- **Ic energie:** Operational carbon emissions, over a 50 years period
- **Ic composants:** Embodied Carbon of the whole building and building lot
- **DH:** degree hours of discomfort in summer

The RE 2020 energy calculation method is roughly the same as the RT 2012, though it now integrates the energy consumption of elevators. The Carbon indicators will be evaluated by a full Life Cycle Analysis.

With the new RE 2020, the French government hopes to fulfil the requirements of the National Low Carbon



Figure 13: RE 2020 Logo

SAMPLE PROJECT

Java is a 9 storeys office Building in Paris, with a total floor area of 24000 m², completed in 2017. The building is part of the renewal of the Clichy-Batignolles district, characterized by the coverage of the rail network leading to St Lazare station. The project is located on the thick slab covering the tracks.

The will of the planning authorities, Paris Batignolles Aménagement (PBA), was to make Clichy Batignolles an exemplary Ecodistrict, through ambitious targets on energy efficiency, use of renewable energies, reduction of greenhouse gas emissions and biodiversity. All new constructions had to comply with highly challenging specification notices, as well as the Paris Climate Plan, and all the required certifications.

Barbanel worked on all the four office buildings in this district, bringing innovative solutions for each of them.

One the most challenging aspects required by PBA was to design a 24 000m² office without the use of any active cooling system, while having demanding targets towards thermal comfort, which had to be assessed through thermal simulations within the frame of an extreme climate change weather.

The window to wall ratio of the façade is around 60%. This ratio is higher for lower floors to increase the incoming of natural light and diminishes with the height to limit solar heat gain in upper floors. The building envelope is designed to be highly efficient, with high thermal resistance values for walls and flat roofs. In summer efficient external venetian blinds allow to minimize solar heat gain. The shading devices are connected to BMS and automated depending on the solar irradiation and temperature.

In such a case, inertia would be the prior aspect to focus on to ensure comfort in office spaces during the hottest periods. Yet the construction site was highly constrained concerning the solutions we could have hoped to install. One of the main façades directly faced the rail network tracks, and the pollution caused by the micro and nano particles in the air prevented from using natural ventilation as the main solution for thermal comfort.

Besides geothermal and geocooling systems could not be a solution as the building is located right on the slab covering part of the tracks.

In this case, the use of inertia via a 46 cm thick active slab appeared as the appropriate solution regarding the previous constraints. The active slab allows the building structure to store energy, using embedded pipes carrying hot or cold water. In order to reduce energy consumption, hot water driven inside the piping system is generated at low temperature for heating, around 27°C, and cold water at high temperature for cooling. Except for fresh air supply, this system does not need any additional ventilation energy.

During heating periods, the active slab is used as a heating base. Natural convection baseboard heaters are installed every two frames as a supplementary heating, to provide comfort adjustment for users.

Figure 14: Project Java rendering





Figure 16: Project JAVA

Fresh air is supplied to AHUs equipped with high efficiency rotary enthalpy heat exchanger, thus allowing to reuse the calories from the extracted air.

The distribution of the technical networks is carried out in the false floor in order to maximize the concrete surface in contact with the space below, and thus to take maximum advantage of inertia.

Heat source is provided by the district heating of Clichy Batignolles, which use direct geothermal heat drawn from the 600 meters deep albien aquifer. It ensures that 85% of the heat is supplied by a renewable energy source.

As required by the planning authorities, a large photovoltaic system of 1700 m² was installed, producing around 330 MWh/year.

As such, JAVA is a model of innovation in environmental and energy matters. Holder of the HQE Excellent level label, it meets the environmental requirements of the ZAC Clichy-Batignolles, which includes photovoltaic production, the limitation of energy consumption and active cooling systems, while keeping the comfort and wellness of the user as top priority.

In terms of energy efficiency, JAVA reaches a primary energy consumption of 47.8 kWh_{ep}/m²·year, within the framework of RT 2012 calculations.

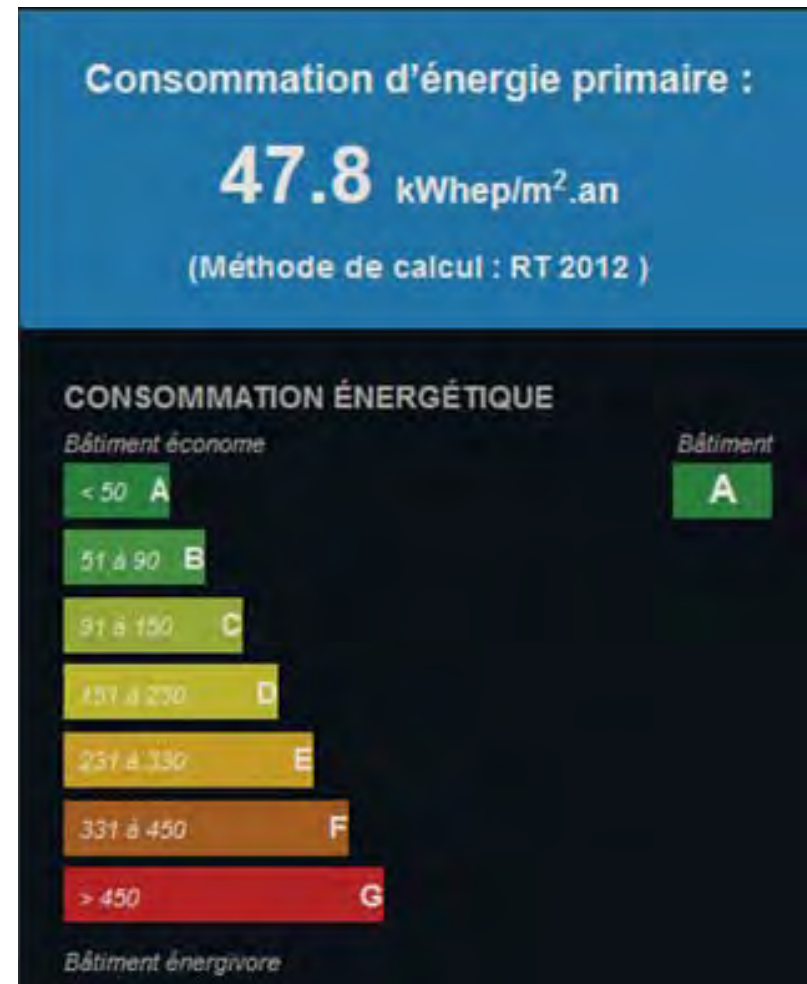

Figure 17: Primary energy consumption

GERMANY



REGULATIONS AND FIRST Q BEST PRACTICE

FIRST Q NETWORK | BUILDING PHYSICS GROUP

GERMANY

COUNTRY REGULATION

Regarding building energy supply in Germany, two main regulations were implemented and observed so far as follows: Energy Saving Ordinance (EnEV 2016) and Act on the Promotion of Renewable Thermal Energy (EEWärmeG). In November 2020, a new building energy law (GEG 2020) was released that basically merges the two mentioned regulations. According to GEG 2020 the requirements for nZEB are defined according to EnEV; The EnEV is a performance-based code that requires a mandatory (equivalent model building) energy frame calculation to establish the expected primary energy consumption of residential and non-residential buildings. The regulation addresses thermal envelope requirements and energy using or producing systems in the calculation, including, HVAC, hot water, lighting (non-residential only), bio-climatic design and renewable energy. Furthermore, the new CO₂ Taxing-Update have been introduced since December 2019 that sets out a clear Carbon Tax road map where the taxes are raised within three time-steps for the CO₂ emission in different energy sectors.

Considering financial initiatives, since January 2020 the Federal Ministry for Economic Affairs and Energy has initiated a new market incentive program for promotion of the use of renewable energy (MAP) which supports the implementation of the renewable energy systems such as heat pumps, biogas and solar energy systems in existing and new buildings.

SAMPLE PROJECT

As a sample project in which ZWP Company was responsible for investigation, design and planning of both building physics and energy concept, is an office building located in Deutz port in Cologne with a GFA of 10.700 m² (see Figure 18). The heating and cooling loads of the building amount to 370 kW and 410 kW respectively.

As passive measures, aiming to increase the passive solar energy use in the building as it can be observed in Figure 2, the surrounding balconies were planned. At the same time in order to prevent the overheating of the building, the intelligent control of sun protection was implemented in the planning of the building. Considering the thermal quality of the building envelope, the detailed analysis of thermal bridges was carried out to minimize the heat loss of the building. Integrating active measures including waste heat recovery from cold storage cells, which are located in the canteen of the building, heat recovery in the ventilation system and free cooling through cooling tower, enabled us to save significant amount of energy and reduce the active heating and cooling demand of the building.

Another important aspect of this project is the investigation of different energy supply variants for the building. As the classic variant (Variant 1), we considered district heating and chiller for heating and cooling respectively, this variant is then optimized in two steps by waste heat recovery and free cooling (Variant 2a, Variant 2b) leading to reduce the primary energy demand as well as CO₂ emission of the building energy system. As the Variant 3, shown in Figure 19, we proposed the groundwater source heat pump system with 370 kW heating capacity for heating purposes, in case of cooling the baseload is supplied directly by open loop groundwater system for base load and a 110 kW chiller is responsible for peak load supply.



Figure 18: Project Kaltenbornweg
[Source: format-architektur.de]

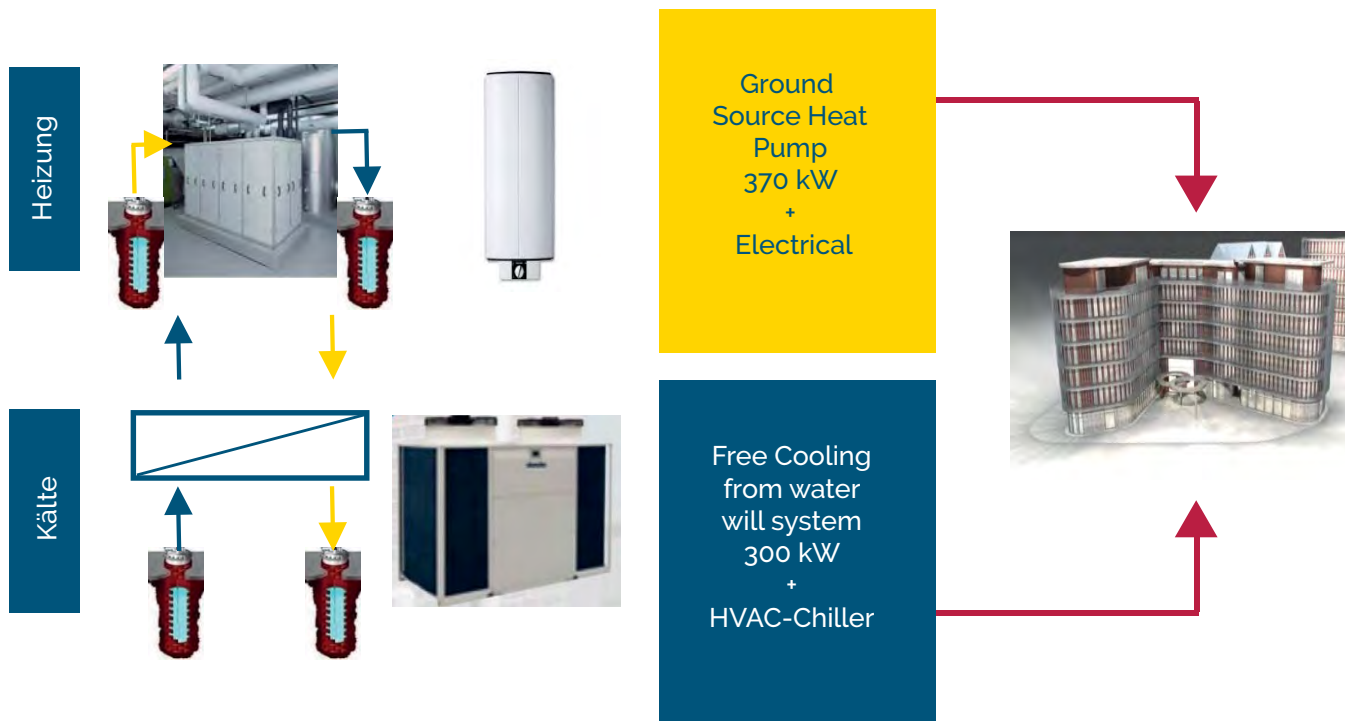

Figure 19: Energy supply concept of the building

As it is illustrated in Figure 20, employing the proposed energy concept enables the significant decrease of the annual primary energy demand and increases the renewable share in end energy use that results in reducing the annual CO₂-Emission by roughly 75% compared with the classic energy variant.

In case of annual operation costs, replacing district heating by geothermal heat pump in variant 3 leads to eliminating the entire annual heating cost imposed by district heating, moreover by using groundwater cooling potential and reducing the size of the chiller the cooling efficiency is increased which also results in cutting the electricity cost of the system; As it is indicated in Figure 21. by applying variant 3 the entire annual operation cost is reduced by almost 70% compared with variant 1.

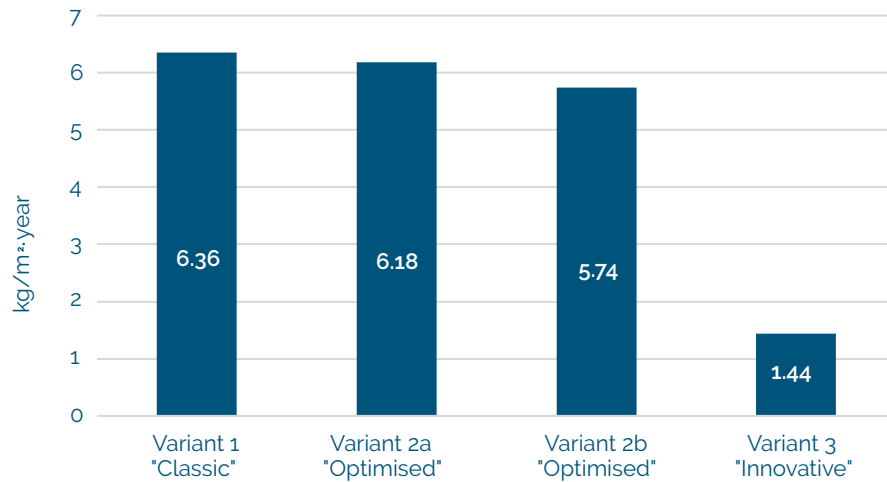

Figure 20: Annual CO₂-Emission of the investigated energy supply variants

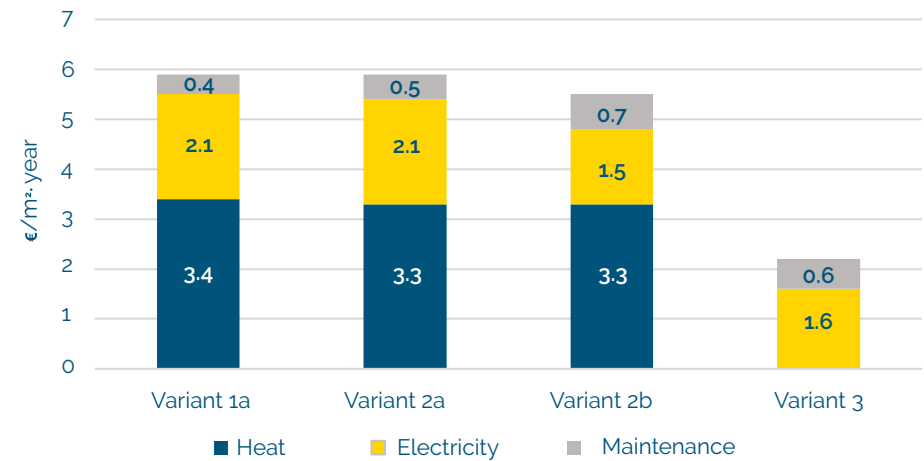

Figure 21: Annual operation costs of the investigated energy supply variants

Figure 22 represents the energy performance certification issued for this building; as it is seen in the energy index, the primary energy demand of the building lies by 43 kWh/m²·a that fulfils the requirement of nZEB according to EnEV regulation. The end energy and net energy demand of the building are other important parameters indicated in the energy graph, which are 20 kWh/m²·year and 90 kWh/m²·year respectively. The net energy demand is the energy that is available after energy conversion, which in this case the amount of heat and cold energy available after heat pump system.

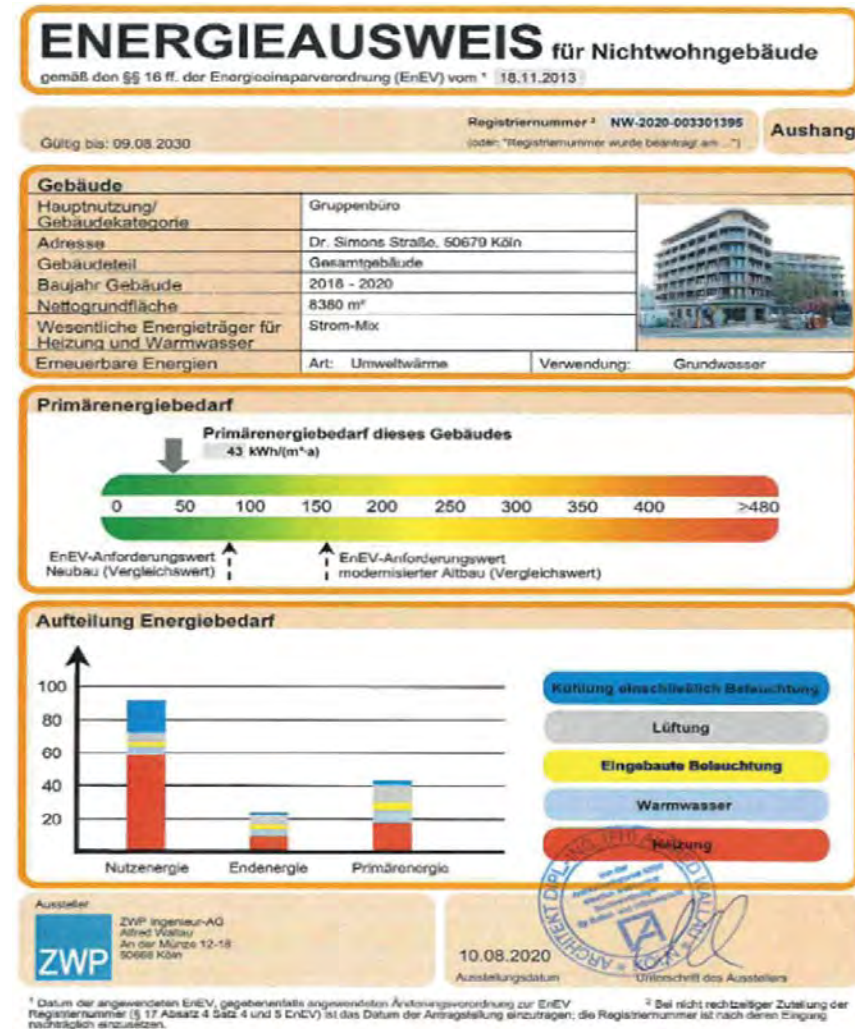

Figure 22: Energy-Performance certificate of the building

IRELAND



REGULATIONS AND FIRST Q BEST PRACTICE

FIRST Q NETWORK | BUILDING PHYSICS GROUP

IRELAND

COUNTRY REGULATION

The Building Control Act 1990 resulted in the implementation of the 1991 Building Regulations (SI 306 of 1991) which were the first proper statutory regulations for building standards in Ireland. These applied from 01/06/1992 to all new buildings as well as to material alterations of buildings and to changes of use of buildings. Ireland transposed the EPBD through the Energy Performance of Buildings Regulations 2003 (S.I. 666 of 2006) which provided for the Building Energy Rating (BER) system to be administered and enforced by the Sustainable Energy Authority of Ireland (SEAI). The SEAI was set up by the government in 2002 as Ireland's national energy authority whose mission is to play a leading role in transforming Ireland into a society based on sustainable energy structures, technologies and practices.

In Ireland, the conservation of fuel and energy is regulated by Technical Guidance Document Part L. There are two versions of this – one for Dwellings (Part L 2019) and one for commercial buildings (Part L 2017). These documents are published by the Department of Housing, Local Government and Heritage. Compliance with Part L is demonstrated via modelling using accredited software which is auditable by SEAI. Application of Part L can require a nuanced approach due to the complexity of the regulations.

DEAP is the software program used for demonstrating compliance to Part L 2019 Dwellings. The DEAP software is the Irish official method to calculate primary energy consumption and related carbon dioxide (CO₂) for domestic buildings. DEAP is a free web-based tool for producing Building Energy Rating (BER) certificate and nZEB compliance assessment.

SBEM is the software program used for demonstrating compliance with Part L 2017 for Building Other than Dwellings. The Simplified Building Energy Model (SBEM) is a calculation engine designed for the purpose of indicating compliance with building regulations Part L with regard to primary energy usage from buildings other than dwellings.

Integrated Environmental Solutions (IES) Virtual Environment (VE) software provides an SBEM interface and has been used for the Part L and BER assessments conducted in this report.

NEAP (Non-Domestic Energy Assessment Procedure) & DEAP (Dwelling Energy Assessment Procedure)

Overview: Methods to demonstrate compliance with TGD Part L

The primary energy consumption and carbon dioxide (CO₂) emissions are calculated using the NEAP (Non-Domestic Energy Assessment Procedure) methodology. The NEAP methodology sets out the procedures to reflect the processes when calculating the 'Energy Performance Coefficient' (EPC), 'Carbon Performance Coefficient' (CPC) and 'Renewable Energy Ratio' (RER).

Under Part L 2017, an nZEB Reference building has been specified which defines the 'Maximum Permitted Energy Performance Coefficient' (MPEPC) and 'Maximum Permitted Carbon Performance Coefficient' (MPCPC). The Reference building is a high-performance building based on the same geometry as the actual design with 20% of its primary energy use met by renewables i.e. (PV). The reference building recipe is to be found in Part L Appendix.

In order to demonstrate that an acceptable primary energy consumption rate has been achieved, the calculated EPC will be no greater than the MPEPC of 1.0. Similarly, to demonstrate that an acceptable CO₂ emission rate has been achieved, the calculated CPC will be no greater than the MPCPC of 1.15.

The RER requires that 20% of the building primary energy use is met via renewable energy technologies. However, for higher performing buildings that achieve EPCs and CPCs ≤ 0.9 and 1.04 respectively, the RER is reduced to 10%. The NEAP and DEAP methodologies are audited by SEAI.

SAMPLE PROJECT

Ethos Engineering were engaged to design the mechanical, electrical and sustainability requirements of a proposed mixed-use commercial / retail development located in Smithfield, Dublin, model image of project illustrated in Figure 23. The project has a GFA of approximately 18,600 m², consisting of a seven-storey commercial office building with retail floor space at ground level and two basement levels for car/bicycle parking and building services plant.

Figure 23: Mixed Use Commercial Project Smithfield, Co. Dublin



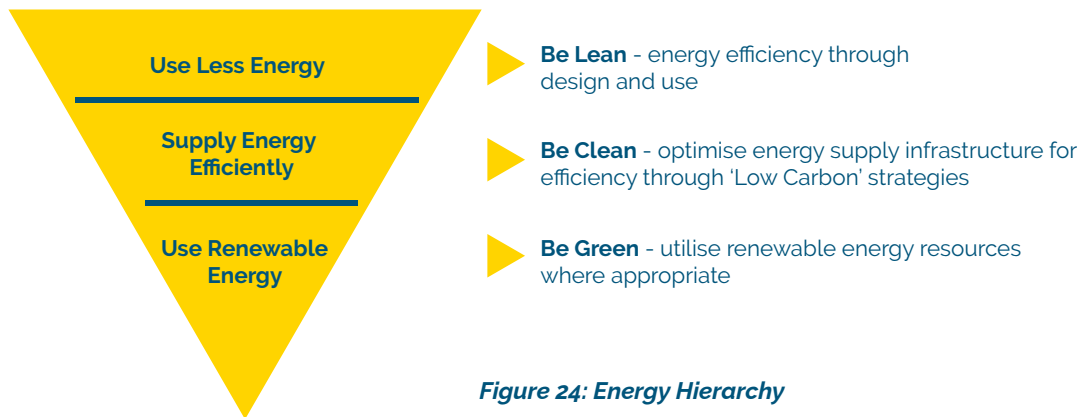

Figure 24: Energy Hierarchy

To achieve, understand and rationalise a pathway for energy efficiency on the project the energy hierarchy, shown in Figure 24, was used to identify and prioritise effective means of reducing carbon emissions for the project.

In adopting the hierarchy, the primary energy use and CO₂ emissions reduction at each stage are maximised before strategies at the next stage are considered. An energy strategy was then developed to ensure the project met the national and EU regulations.

Passive Solar Design

Passive solar design is of utmost importance in large commercial buildings where cooling constitutes a significant portion of the energy demand. The proposed façade design minimises solar heat gain via a combination of glazing specification, spandrel panels and local shading fins on the East, South and West façades. The proposed façade design was developed over an iterative process of verification against the Part L criteria in IES.

The new development was designed and constructed to limit heat loss and where appropriate, limit heat gains through the fabric of the building. In order to limit the heat loss through the building fabric the thermal insulation for each of the plane elements of the development will meet or exceed the area weighted average elemental U-Values as specified in Part L, refer to Table 6 for the targeted U-Values.

Guardian Sunguard SNX50 is installed in the façade and includes a triple silver coating allowing over twice the amount of natural light to solar heat gain. This highly selective glazing has a light transmittance of 50% and a g value of 24%.

Table 6: Fabric U-Values

Element	Part L 2017 U-Values (W/m ² K)	Targeted U-Values (W/m ² K)
Flat roof	0.20	0.15
Walls	0.21	0.20
Ground Floors	0.21	0.15
Exposed floors	0.21	0.15
External personnel doors and windows	1.6	1.5
Roof lights	2.2	2.2
Insulation curtain wall spandrel panels	1.8	1.5

HVAC SYSTEM DESIGN

Following a Low or Zero Carbon (LZC) technologies feasibility study, it has been concluded that 4-pipe heat pump chillers and solar Photovoltaic (PV) are the most suitable renewable energy technologies to be utilised in the proposed development.

The mechanical ventilation plant strategy is to maximise the efficiency of the HVAC systems through the use of heat recovery and the efficient control of both ventilation rates and of heating and / or cooling supply. The HVAC performance values are noted in Table 7.

Table 7: HVAC Summary

Element	Design Target
Heating SCoP	3.70
Chiller SEER	3.97
Multi-pipe chiller Total Efficiency Ratio	8.35
Heat Recovery eff.	80%
Central AHU SFP (including thermal wheel & heat pump)	2.3 W/L/sec

The main features of the HVAC plant are the use of multi-pipe chillers for heating and cooling and a Dedicated Outdoor Air Handling System (DOAS) AHUs incorporating two stage heat recovery via thermal wheel and integrated heat pump. These Recooler AHU heat pumps achieve very high COP and EERs due to the almost constant air temperature achieved by the air having gone through the thermal wheel. Domestic Hot Water is generated using an Aermec WWB water-to-water booster heat pump. No fossil fuels are used in the central plant.

A four-pipe fan coil system is installed in each area to trim the air temperature to suit the local room environment. These use fans with EC motors resulting in low Specific Fan Powers.

Multi-pipe or 4-pipe chillers are particularly suitable in a country like Ireland. Because the island is hugged all year round by the warm influence of the Gulf Stream, Ireland is much warmer than other countries that share its latitude with mild winters. Winters tend to be cool and windy, while summers are mostly mild and less windy. Ireland does not suffer from the extremes of temperature experienced by many other countries at similar latitude. Multi-pipe air source chillers are best placed to exploit this renewable energy which is readily available in our mild moist air.

The 4-pipe heat pump chiller uses heat pump technology and heat recovery to simultaneously generate cooling and heating for the development.

These operate in three different modes depending on the load demand of the development;

- Cooling demand only
- Heating demand only
- Simultaneous cooling and heating demand - during this demand, the heat pump operates in cooling mode but captures waste heat that is normally lost and rejected to atmosphere. This free energy is then used for the heating demand and hot water generation for the development.

A highly efficient lighting design achieving close to 1 W/m²/100 lux is installed in the office area and controlled using daylight and occupancy.

Building Energy Rating Certificate

The office building design is achieving a (BER) certification of 'A3'

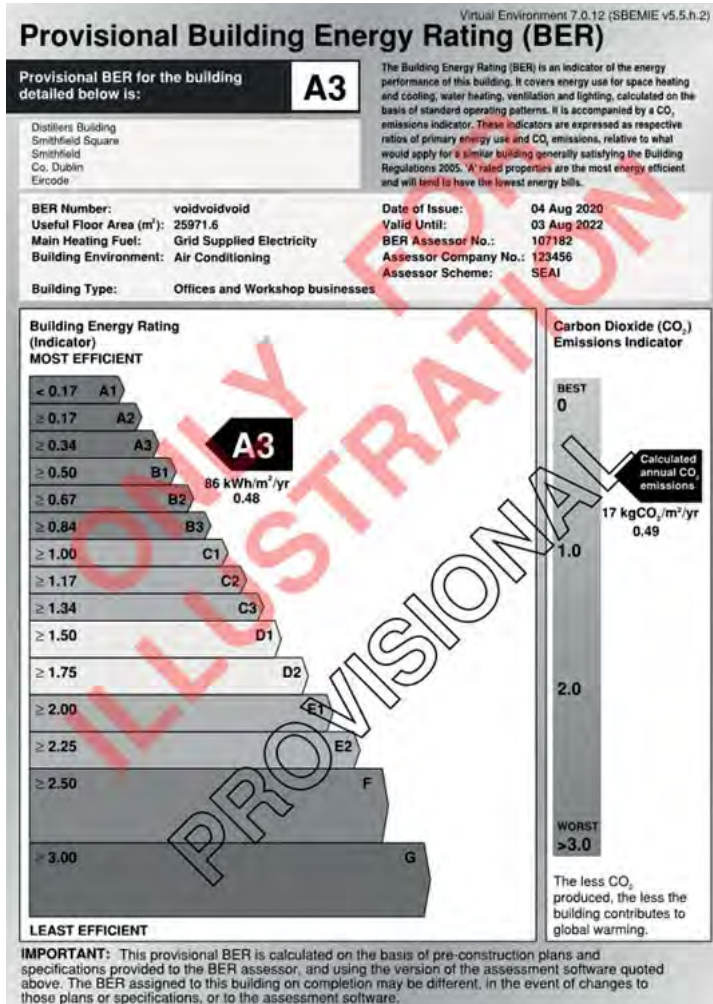

Figure 25: Provisional Building Energy Rating (BER)

BRIRL Compliance Report

Figure 26 details the BRIRL output document which details how the project has complied with the regulations and the performance values achieved within the project.

BRIRL Output Document

Compliance Assessment with the Building Regulations (Ireland) TGD-Part L 2017

This report demonstrates compliance with specific aspects of Part L of the Building Regulations. Compliance with all aspects of Part L is a legal requirement. Demonstration of how compliance with every aspect is achieved may be sought from the Building Control Authority.

Distillers Building BRIRL

Date: Mon Aug 17 14:26:48 2020

Administrative Information

Building Details

Address: Distillers Building, Smithfield Square, Smithfield, Dublin 7, Co. Dublin, Eircode

Client Details

Name: Lindens of Smithfield Limited
Telephone number: +353 (0)1 864 8212

NEAP

Calculation engine: SBEMIE
Calculation engine version: v5.5.h.2
Interface to calculation engine: Virtual Environment
Interface to calculation engine version: 7.0.12
BRIRL compliance check version: v5.5.h.2

Energy Assessor Details

Name: Abdulhamid Alhethali
Telephone number: Phone
Email: you@yourISP
Address: Apex Business Centre, Blackthorn Road, Smithfield, Dublin 18, Dublin 18, Eircode

Primary Energy Consumption, CO₂ Emissions, and Renewable Energy Ratio

The compliance criteria in the TGD-L have been met.

Calculated CO ₂ emission rate from Reference building	18.3 kgCO ₂ /m ² .annum
Calculated CO ₂ emission rate from Actual building	16.4 kgCO ₂ /m ² .annum
Carbon Performance Coefficient (CPC)	0.9
Maximum Permitted Carbon Performance Coefficient (MPCPC)	1.15
Calculated primary energy consumption rate from Reference building	94.6 kWh/m ² .annum
Calculated primary energy consumption rate from Actual building	83.3 kWh/m ² .annum
Energy Performance Coefficient (EPC)	0.88
Maximum Permitted Energy Performance Coefficient (MPEPC)	1
Renewable Energy Ratio (RER)	0.2
Minimum Renewable Energy Ratio	0.1

Heat Transmission through Building Fabric

Element	U _{Lim}	U _{Calc}	U _{Lim}	U _{Calc}	Surface with maximum U-value*
Walls**	0.21	0.12	0.6	0.2	B0000002_W1_A0
Floors (ground and exposed)	0.21	0.13	0.6	0.15	B000000B_F_A0
Pitched roofs	0.16	-	0.3	-	"No heat loss pitched roofs"
Flat roofs	0.2	0.15	0.3	0.15	L000000F_C_A1
Windows, roof windows, and rooflights	1.6	1.5	3	1.5	L0000001_W3_O1
Personnel doors	1.6	1.5	3	1.5	L0000001_W3_O0
Vehicle access & similar large doors	1.5	-	3	-	"No ext. vehicle access doors"
High usage entrance doors	3	-	3	-	"No ext. high usage entrance doors"

U_{Lim} = Limiting area-weighted average U-values [W/(m²K)]
U_{Calc} = Calculated area-weighted average U-values [W/(m²K)]
U_{Lim} = Limiting individual element U-values [W/(m²K)]
U_{Calc} = Calculated individual element U-values [W/(m²K)]
* There might be more than one surface with the maximum U-value. ** Automatic U-value check by the tool does not apply to certain walls whose area-weighted average and individual limiting standards are 1.8 and 3 W/m²K, respectively.

Air Permeability	Upper Limit	This Building's Value
m ³ /(h.m ²) at 50 Pa	5	3

Figure 26: BRIRL Output Document

ITALY



REGULATIONS AND FIRST Q BEST PRACTICE

FIRST Q NETWORK | BUILDING PHYSICS GROUP

ITALY

COUNTRY REGULATION

Italian regulation on building energy is quite complex. Essentially, the reference law is the D.Lgs 192/2005, that represent the implementation of EU Directive on Energy Performance in Buildings (EPBD). More in detail, the last and more significant implementing decree of the previous law, the D.M. 26/06/2015, defines the minimum requirements (for facade insulation, windows, efficiency, energy consumption indexes, equipment efficiency, etc) for the different building project categories, from new construction to renovation, with different goals based on date of construction permit. "Minimum requirements", that is also the common name of this decree, can be derogated as long as the calculated consumption indexes (heating, cooling, domestic hot water) are better than baseline building (same building as design but with minimum requirements implemented), with an approach similar to ASHRAE 90.1 for dynamic simulation, but using a simplified quasi-steady state method, as defined in other UNI standards.

In short, the mentioned decree, after defining the energy certification rating methodology, also gives the definition of nZEB as the buildings, whether new or existing, simultaneously satisfying the following conditions.

- 1.** All the following minimum requirements with the values in force from 2019 for public buildings and from 2021 for all other buildings, including:
 - a. average envelope transmittance value: based on climate zone, surface/volume ratio, project category and insulation for wall, roof, windows and basement;
 - b. solar area: fraction of fenestration surfaces over gross building surface, corrected with all related items (glass shading factor, shading, overhang, etc.);
 - c. performance index: calculated with standardized method for (1) space heating, (2) space cooling and (3) global value (heating, cooling, DHW, ventilation, lighting, internal transportation);
 - d. average seasonal efficiency for equipment, for (1) space heating, (2) DHW and (3) space cooling (with humidity control).

- 2.** The obligations of integration of renewable sources in compliance with Legislative Decree n. 28/2011, that, scaling by date of construction permit invitation (2012-2014-2018), requires after 2018 that:
 - a. at least 50% of the energy consumption for space heating, space cooling and domestic hot water are generated from renewables, with exception of full electricity-based system. If a district heating is available, the minimum renewable percentage as above is not necessary.
 - b. All buildings shall install a photovoltaic system with total rated peak power, in kW, higher than 1/50 of the building footprint expressed in square meters.

Furthermore, for public buildings, the obligations referred to in the previous paragraphs are increased by 10%.



Figure 27: Project rendering by Skidmore, Owings & Merrill

SAMPLE PROJECT

Originally designed in the early 1960s by architects Gio Ponti, Piero Portaluppi, and Antonio Fornaroli as the Milan headquarters of Allianz S.p.A., the building has contributed for 50 years to consolidate the identity of the area around Corso Italia and Via Santa Sofia, describing the story of the city and the neighbourhood to which the complex is inseparably linked. In 2018 all Allianz's Milan offices moved to the new location in Milan, so the Corso Italia 23 property began a process of redevelopment with an international tender, awarded to SOM (Skidmore, Owings & Merrill).

The 45,000 m² renovation project will be transformed from an insular single-tenant headquarters into a vibrant office campus that represents the future of the workplace. The design proposal employs the most advanced sustainability, flexibility, wellbeing, and smart building concepts while respecting and maintaining a dialogue with the original design.

The design activity pursued the client's requests for a "best in class" renovation project that proposed a cutting-edge, attractive and high commercial profile building. The design goals were identified with the entire design team using a holistic approach and an integrated process that led to an excellent level of comfort in the interior spaces, health and well-being for its occupants, low environmental impact both during construction and operation and to the achievement of nZEB status according to local regulation.

Embracing all aspect of sustainability—environment, resource management, and people—the project is designed to meet both LEED Gold and WELL Gold. In addition, through the adoption of a BIM design process, it was possible to rationalize design activities and ensure an efficient, transparent, and effective data exchange and availability system for the entire supply chain.

The energy strategy of this project is based on three fundamental aspects: reduction of energy demand, efficiency of MEP systems, and renewable sources. This approach to a zero energy renovation balances heritage, innovation, cost, and sustainability.

To define the most appropriate energy strategy, a preliminary energy model "simple box" was carried out from the beginning to simulate the energy requirements in EnergyPlus using an "ideal load" calculation. An accurate simulation has been performed during the subsequent project development phases. The energy model was adopted as a design tool for optimizing different building performance, including MEP systems, façades, daylighting. Since the early phase of design, simulation tools were used in order to assess the solar gain on the southern sides and thus optimise the facades performance while improving daylight and visual comfort for interior spaces.

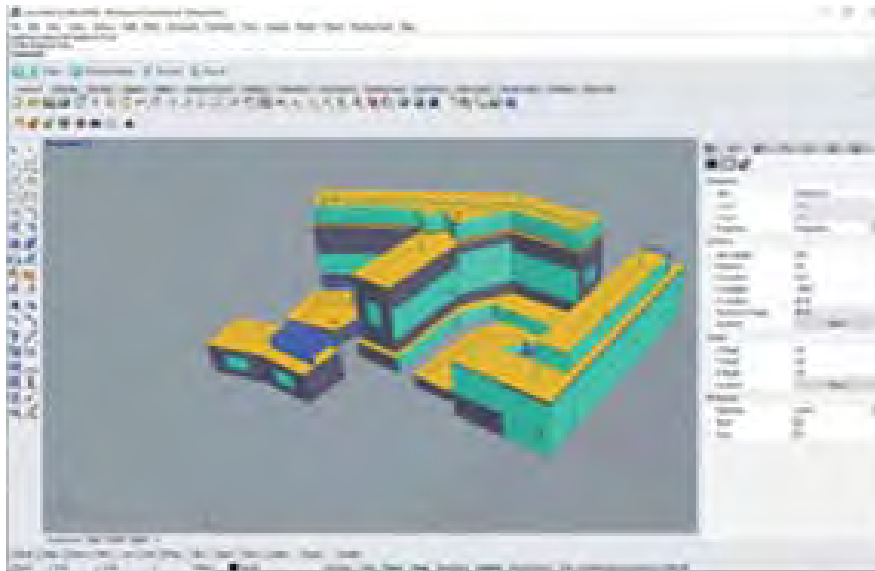

Figure 28: Early phase energy modelling



Figure 29: Axonometric view of the project



Figure 30: Rendering of the building B façade

Building A, facing the main road (Corso Italia), defines the campus' new identity with an external high performance cladding system that will be custom assembled, consisting of metal-framed granite screens, glass, and aluminium curtain wall panels. The external existing concrete frames, which give the character to the façade, will be kept as they are and restored, repairing the original finishing, while the thermal insulation will be improved internally. Based on the modelling results, the design team was informed to insert a high-performance insulating glass that will be glazed into natural anodized aluminium frames, coupled with internal micro-blinds for shading.

For the renovation of the Building B, Existing Heritage external plaster is being retained and new custom designed aluminium and glass windows will be installed. The building will be clad with natural stone and will be installed with new aluminium frames windows. Moreover, the exterior wall assembly will include thermal insulation, vapour barrier, louvres, doors and all necessary flashings, sealings and support fixings.

Figure 31: Rendering of the building A facades



Office buildings can be considered among the most energy-intensive, if not carefully designed, and MEP systems play a key role in the health and well-being of the occupants. The project has taken all these aspects into account to achieve a state-of-the-art solution, including full BIM design.

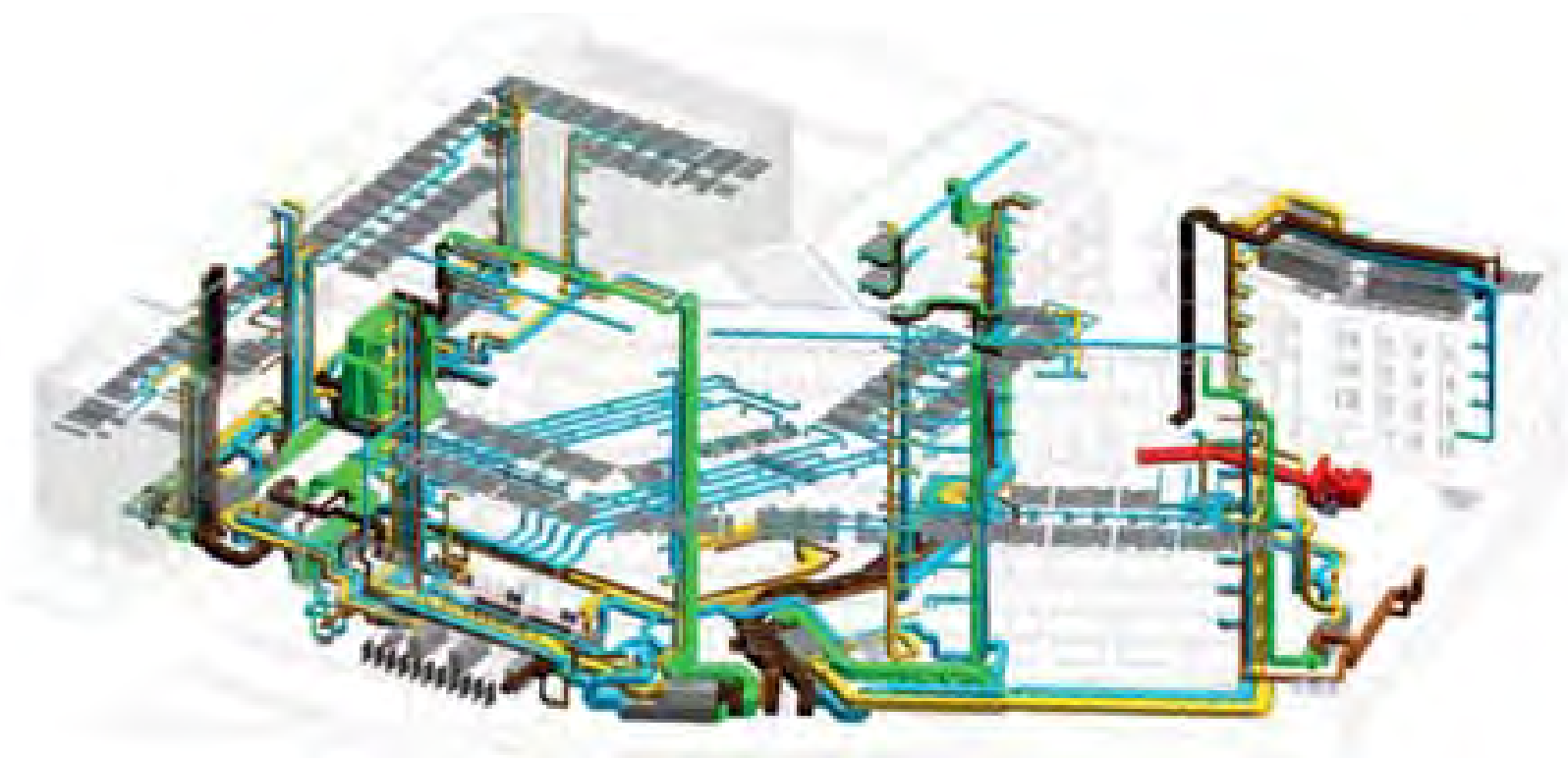

Figure 32: HVAC systems BIM design

The office areas are based on radiant ceilings for heating and cooling, together with air supply from centralised air handling units (AHUs), located either at roof or basement levels; this gives the best performance in terms of comfort, low energy consumption, and reduced maintenance costs. In the mid-season, free cooling for air handling units provides the building with 100% non-heat-treated (filtered only) outdoor air, with significant energy savings. This solution removes the existing under-window fan coil units, brings benefits in flexibility for space planning and allows the replacement of existing facades where required.

Enthalpic wheels in the air handling units provide high-efficiency heat recovery from the exhaust air through a total exchange of enthalpy with the external air intake, while the use of groundwater allows for the production of heating and cooling both directly (mid-season) and via a reversible heat pump, moving toward a carbon-free building.

In order to minimize fossil fuel consumption during building life cycle, renewable energy was preferred for the project, including heat pumps as the only heating and cooling generation system and a large photovoltaic array installed on building roof with 156 kW peak power, higher than minimum requirements from local regulation (100 kWp). These solutions allowed to achieve nZEB status ("Edificio a Energia Quasi Zero") with 74% of total annual consumption from renewables, as calculated with local standards.



Figure 33: Energy certification for one of the building blocks

LITHUANIA



REGULATIONS AND FIRST Q BEST PRACTICE

FIRST Q NETWORK | BUILDING PHYSICS GROUP

LITHUANIA

COUNTRY REGULATION

Lithuania has been involved in a deep change of building design since 2005.

The Law of the Republic of Lithuania on Construction (Official Gazette, 1996, No 32- 788; 2001, No 101-3597) provides for minimum energy performance requirements for all buildings in Lithuania, and the Construction Technical Regulation STR 2.01.02:2016 'Energy Performance Designing and Certification of Buildings.' (hereinafter referred to as 'CTR') (Official Gazette, 2016, No D1 754) establishes requirements for evaluating energy performance.

The calculation method referred to in the standard LST EN 15217:2007 'Energy performance of buildings – Methods for expressing energy performance and for energy certification of buildings' is used for evaluating energy performance of buildings. In Lithuania, energy performance is unrelated to a particular numerical value of energy consumption and is defined by the respective class of energy performance of the building.

According to energy performance, buildings are classified into 9 classes: A++, A+, A, B, C, D, E, F, G.

The Lithuanian legislation setting requirements for the energy performance of buildings does not use reference buildings. Each building is assessed individually. The requirements are based on the following principle: the legislation sets regulatory requirements for the heat characteristics of building envelopes, efficiency of engineering systems (cooling, preparation of domestic hot water, indoor lighting), energy consumption for cooling the building and other indicators for different buildings of class D, C, B, A, A+, A++. The legislation lays down analogous indicators for reporting buildings (of class D and E) (average indicator values of 50% of certain buildings using the lowest amount of energy).

The energy performance class of the building is identified on the basis of the following building indicator values (the compliance of all those values with the legislative requirements is assessed):

- calculated specific heat losses of building envelopes;
- building air-tightness;
- technical indicators for mechanical cooling system with recuperation;
- C1 indicator value of energy efficiency of the building, characterising primary non-renewable energy efficiency for heating, ventilation, cooling and lighting;
- C2 indicator value of energy efficiency of the building, characterising primary non-renewable energy efficiency for preparing domestic hot water;
- part of renewable energy used in the building.

The Law of the Republic of Lithuania on Renewable Energy (Official Gazette, 2011, No 62-2936) contains an initial definition of the concept of a nearly zero-energy building.

In Lithuania, a nearly zero energy building is a building that has a very high energy performance established in accordance with the normative technical construction documents. The nearly zero or very low amount of energy required should be covered to a very significant extent by energy from renewable resources, including energy from renewable sources produced on-site or nearby.

According to the established indicators, a building of class A++ must comply with the applicable parameters:

1. Values C_1 and C_2 of energy efficiency indicators of the building must comply with the requirements of the Regulation, i.e. $C_1 < 0,30$ and $C_2 \leq 0,70$;
2. Calculated specific heat losses of building envelopes must not exceed the normative heat losses;
3. Air-tightness of the building must comply with the requirements of the Regulation, i.e. in case of pressure difference of 50 Pa between the inside and outside of the building, air circulation must not exceed 0.6 times per hour;
4. If a building is equipped with a mechanical ventilation system with recuperation, the recuperator performance ratio shall be at least 0.80, and the amount of energy used by a recuperator ventilator must not exceed 0.45 Wh/m^3 ;

A part of energy from renewable resources consumed in the building shall comply with the requirements of the Regulation, i.e. in buildings of class A++, energy from renewable resources must form the largest part of energy consumed.

SAMPLE PROJECT

New office building "FLOW", developed by EIKA, will be built on Lvovo str. 21A in Vilnius (gross floor area - 22.493 sq.m). The building consists of two main sections. The lower part of the building is 15 floors and the higher part - 20 floors. Each floor is 2,80m high. Both sections of the building have the same dimensions - 15,51m length and 32,66m width. Reflecting the functionality and orientation of the building, windows with different parameters were chosen by the design team. The heating will be generated and supplied by the local heat pump combined with the district heating system. The same heat pump will be used as the main source for the cooling system. A dynamic energy simulation has been carried out to get precise heating/cooling loads. The project is also seeking to get certified by BREEAM and WELL assessment systems.



Figure 34: Office building "FLOW" in Vilnius

Table 8: Project overview

Actual building performance
Heat transfer coefficient of elements of construction U, W/m²K
Stairway wall 0,15
Roof 0,13
External slab 0,13
Floors on the ground for heated zones in underground parking 0,16
Slab above unheated parking 0,16
Walls between heated and unheated underground zones 0,20
Doors 1,60
Facade system opaque elements 0,26
Facade system transparent elements 0,80 (g- value for windows NE- 0,50, for SE, SW, NW- 0,40)
Thermal bridges
Taken from STR 2.01.02:2016 „Pastatų energinio naudingumo projektavimas ir sertifikavimas “.
Air tightness
Tightness of the building value n _{50, N} (1/h) is 0,6 at 50 Pa pressure difference.
Lighting
Lamps with LEDs. Index of lighting equipment efficiency - 150 (lm/W).
External shading
Building component (lamellae), 0,40 m length from façade, 1,40 m distance between each other
Ventilation
Central ventilation SFP- 1,98 W/L/s
Heat recovery efficiency- 75%
Cooling
Air source heat pump. EER = 4,75
Heating
Air to water heat pump. SCOP = 4,65 (Heat pump works till outside dry-bulb temperature reaches -10 oC)
Heating and cooling systems have control devices, building users can control their thermal comfort

PROJEKTUOJAMO PASTATO ENERGINIS NAUDINGUMAS

1 lapas / 2 lapų

Pastato (jo dalies) unikalus pastato numeris: 4400-5103-0480
 Pastato adresas: Lvovo g. 21A, Vilniaus m., Vilniaus m. sav.
 Pastato (jo dalies) paskirtis: Administracinės paskirties pastatai
 Pastato (jo dalies) šildomas plotas, m²: 15762,73
 Viso pastato šildomas plotas, m²: 15762,73
 Pastatų (jų dalių) energinio naudingumo klasifikavimas | klasės*:

Nustatyta pastato (jo dalies) energinio naudingumo klasė:



* A++ klasė laikoma aukščiausia, ji nurodo energijos beveik nevartojantį pastatą, G klasė nurodo energiškai neefektyvų pastatą

Skaičiuojamosios metinės rodiklių vertės vienam kvadratiniam metrui pastato (jo dalies) šildomo ploto:	
Neatsinaujinančios pirminės energijos sąnaudos, kWh/(m ² ·metai):	106,35
Atsinaujinančios pirminės energijos sąnaudos, kWh/(m ² ·metai):	28,26
Metinių atsinaujinančios pirminės energijos sąnaudų santykio su metinėmis neatsinaujinančios pirminės energijos sąnaudomis vertė, vnt.:	1,01
Šiluminės energijos sąnaudos pastatui šildyti, kWh/(m ² ·metai):	7,29
Šiluminės energijos sąnaudos pastatui vėsinti, kWh/(m ² ·metai):	10,67
Šiluminės energijos sąnaudos karštam buitiniam vandeniui ruošti, kWh/(m ² ·metai):	13,18
Suminės elektros energijos sąnaudos, kWh/(m ² ·metai):	36,20
Elektros energijos sąnaudos patalpų apšvietimui, kWh/(m ² ·metai):	0,90
Pastato į aplinką išmetamas CO ₂ kiekis, kgCO ₂ /(m ² ·metai):	19,23

Figure 35: Energy-Performance certificate of the building

PORTUGAL



REGULATIONS AND FIRST Q BEST PRACTICE

FIRST Q NETWORK | BUILDING PHYSICS GROUP

PORTUGAL

COUNTRY REGULATION

In terms of energy efficiency in buildings, there is a regulation focused on non-residential buildings (RECS – Regulamento de Desempenho Energético dos Edifícios de Comércio e Serviços) and another regulation focused on residential buildings (REH – Regulamento de Desempenho Energético dos Edifícios de Habitação) since 2013, integrated in the decree-law DL118/2013 that also approved the national building certification system (SCE). They result from the Directive on Energy Performance in Buildings (EPBD) 2010 recast transposed into national law. In 2019 there was a legislative update regarding the nZEB requirements with the release of two new regulations, one for each type of building:

- Non-residential buildings - Portaria n.º 42/2019 regarding the design requirements for the building envelope quality and efficiency of technical systems;
- Residential buildings – Portaria n.º 98/2019 regarding the design requirements for heating and cooling demands;
- Regarding Non-residential buildings, all new buildings are required to be nZEB from 1st January of 2021 and for that they have to fulfill the following requirements:
- Maximum values for the IEEs (Indicador de Eficiência Energética – Energy Efficiency Indicator) and RIEE (IEE ratio) depending on the building situation

Building situation	Requirement	
nZEB	$IEE_s \leq 75 \% IEE_{s,ref}$	$R_{IEE} \leq 0,50$
New buildings (before 2021)	$IEE_s \leq 100 \% IEE_{s,ref}$	$R_{IEE} \leq 1,00$
Building with major intervention		$R_{IEE} \leq 1,50$

IEEs – represents the energy consumption (primary energy/square meter) that are effectively considered for calculating the building's energy rating.

IEEs,ref – indicator obtained by energy simulation based on reference values.

$IEES \leq 75 \% IEEs,ref$ means that the envelope and the technical systems (HVAC, Lighting, etc ...) must contribute to the building reaching this level without recourse to renewable energy.

To fully define the energy consumption of a building, two other energy indicators are considered IEE and IEEt, which are related by:
 $IEE=IEEs+IEEt$

$$IEE=IEEs+IEEt$$

Where IEE represents the global energy consumption and IEEt represents other consumptions not related with HVAC or lighting.

The conversion factor between final and primary energy applied is $2,5 \text{ kWh}_{ep}/\text{kWh}$.

The R_{IEE} gives the energy class for the building and $R_{IEE} \leq 0,50$ represents minimum A class

- Building Management Systems shall comply with the minimum requirements of class B defined in Table 5 of standard EN15232
- The design of technical systems in non-residential buildings should involve studying the implementation of solutions for the use of renewable energy sources that, regardless of the provision for the use of solar thermal energy in domestic hot water production (DHW), must cover at least the following elements:
 - 1) Photovoltaic solar systems;
 - 2) Biomass based systems, for heating and DHW production, in municipalities where there is an integrated network for the collection of forest waste;
 - 3) Systems for the use of geothermal energy, for heating and DHW production, in places with geothermal resources with a temperature above 40 °C.
- The installation of biomass cogeneration systems in new non-residential buildings, characterized by significant heating and DHW demands, is mandatory, unless it demonstrates economically unviable.

Regarding Residential buildings, it is not yet defined when the buildings will have to comply the nZEB requirements. However, they have to fulfill the following requirements:

- The value of the annual nominal demands for useful energy for heating (N_{ic}) must be less than or equal to 75% of their maximum value (N_i) - This means that the building heating demand must be less than 75% than the reference, it implies that constructive solutions must have a big impact in the winter.
- The value of the nominal primary energy demand (N_{tc}) for nZEB buildings must be less than or equal to 50% of their maximum value (N_t). - After meeting the winter requirement above, the building must have a minimum energy class of A.
- Renewable energy sources must supply at least 50% of annual primary energy demands.

The Directive (EU) 2018/844 - EPBD (Energy Performance of Buildings Directive), is currently being transposed which will update the current regulations.

SAMPLE PROJECT

As a sample project, we present an office building located in Lisbon with a GFA of 15690 m² where LMSA is responsible for designing the building physics and energy concept.

In order to achieve nZEB classification according to the current legislation, its thermal envelope and the systems energy efficiency must show an improvement in relation to the values considered as reference.

Regarding the envelope, two types of exterior walls (PE) were considered, one type of exterior roof (COBEXT) and external floor (PAVEXT). The following table shows the values of the thermal transmission coefficient for each type of element and the reference values:

Table 9: Building envelope

Element type	Building U-Values	Reference U-Values
	(W/m ² ·K)	(W/m ² ·K)
PE1	0,50	0,7
PE2	0,66	0,7
COBEXT1	0,47	0,5
PAVEXT1	0,48	0,5

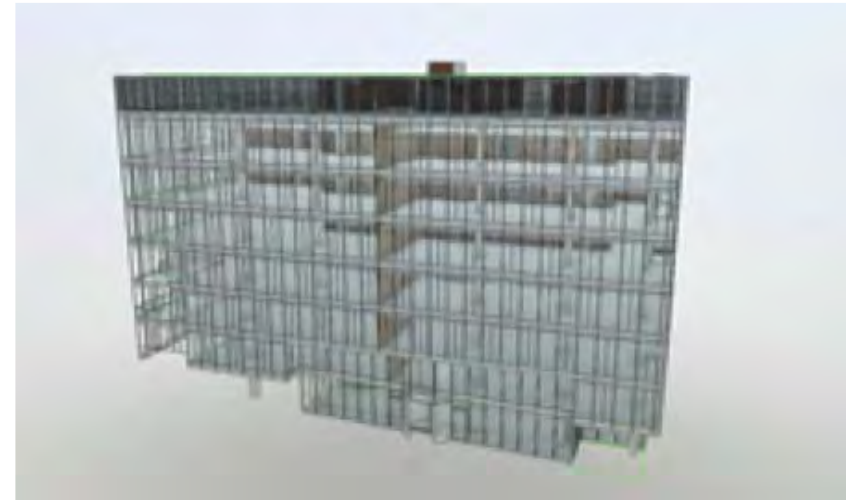

Figure 36: Project Metropolis

Regarding the glazed façades, double glass with 16mm argon gap were considered. It was also considered the interior shading effect with light translucent roller shades and exterior left and right fins. From these assumptions we can get the following characteristics:

Table 10: Building glazing

Glazing	Building		Reference	
	U-Value (W/m ² ·K)	Solar Factor	U-Value (W/m ² ·K)	Solar Factor
VE1	1,8	0,15	4,3	0,20

The main HVAC centralized system equipment is subject to minimum efficiency requirements according to the legislation and therefore high efficiency equipment was specified.

The thermal power plant consists of two water-cooled heat pump chillers and one air-cooled heat pump chiller as backup. With this solution is possible to take advantage of the best energy efficiency at full load and partial load of the water-cooled chillers during most of the year. In Heating mode, during periods of the year when the enthalpy of the outside air does not allow the cooling towers operation, the production of thermal energy will be ensured by the alternative system, consisting of a heat pump type air-cooled chiller.

Table 11: Chillers efficiency

Units	Building		Reference	
	EER	COP	EER	COP
CH1 WC	5,52	4,33	4,65	4,15
CH2 WC	5,52	4,33	4,65	4,15
CH3 AC	4,14	3,75	2,90	3,00

For air handling units (UTAN) and distribution pumps (BC, BFP, BFS, BQP, BQS) the same principle was applied as represented in the following figure.

Table 12: AHU and pumps efficiency

Units	Building			Reference		
	Motor ¹⁾	SFP ²⁾ W/(m ³ /s)		Motor ¹⁾	SFP ²⁾ W/(m ³ /s)	
		Supply	Return		Supply	Return
UTAN 1	IE3	1070	870	IE2 ³⁾	1250	1250
UTAN 2	IE3	1190	1020	IE2 ³⁾	1250	1250
UTAN 3	IE3	1120	1010	IE2 ³⁾	1250	1250
BC 1-3	IE5	-	-	IE2 ³⁾	-	-
BFP 1-3	IE5	-	-	IE2 ³⁾	-	-
BFS 1-3	IE5	-	-	IE2 ³⁾	-	-
BQP 1-3	IE5	-	-	IE2 ³⁾	-	-
BQS 1-3	IE5	-	-	IE2 ³⁾	-	-

¹⁾ according to standard IEC60034-30

²⁾ specific fan power

³⁾ Level IE2, if the motor is equipped with a speed variator

Regarding lighting, the following requirements were verified:

Table 13: Lighting requirements

Space	LUX	Building		Reference	
	(EN 15193)	W/m ² /100Lux	W/m ²	W/m ² /100Lux	W/m ²
Offices with more than 6 people	500	1,0	5,0	2,1	10,5
Corridors	100	3,8	3,8	3,8	3,8
Toilets	200	3,8	7,6	3,8	7,6
Technical areas	300	3,4	10,2	3,4	10,2
Storage rooms	200	3,4	6,8	3,4	6,8
Parking lots	300	0,7	2,0	3,4	10,2

After gathering and processing this information, energy simulations were done and the IEE_s , $IEE_{s,ref}$ and R_{IEE} values were calculated. The $IEE_{s,ref}$ is obtained by introducing reference values for the envelope, equipment efficiency, fresh air rates and lighting densities. Additionally, a photovoltaic solar system with 300-panel is foreseen. The values of the calculated indicators are as follows:

Table 14: Energy indicators

IEE	IEEt	IEE_s	$IEE_{s,ref}$	R_{IEE}
kWh _{ep} /m ² .year	kWh _{ep} /m ² .year	kWh _{ep} /m ² .year	kWh _{ep} /m ² .year	
145,4	66,7	105,5	149,2	0,37

These values ensure the building A class ($R_{IEE} \leq 0,50$) and $IEE_s/IEE_{s,ref} \leq 0,75$.

SPAIN



REGULATIONS AND FIRST Q BEST PRACTICE

FIRST Q NETWORK | BUILDING PHYSICS GROUP

SPAIN

COUNTRY REGULATION

Spain has been involved in a deep change of building design since 2006, when the National Construction Code CTE/2006 came into effect; and that was, mostly, because it addressed several aspects regarding thermal demand limitation, HVAC & lighting system's efficiency and the inclusion of renewable energy for Domestic Hot Water production and electricity generation. At the same time, the European Directive 2002/91/CE was implemented in Spain by the RD 47/2007 and, thus, all buildings started being energy classified with the official building energy simulation tools provided. Both regulations entailed huge changes in building design in a transversal way, from architecture to installations.

By December 2019, the New Building Code CTE/2019 subscribed under the nZEB frame was published. This latest version represented a deep overhaul of the previous one because it introduces two absolute values for residential and non-residential buildings according to its climate zone and Internal Mean Load:

Annual Total Primary Energy (kWh/m²): maximum global value of primary energy that can be supplied to the building. It includes both the energy supplied and produced on site, as well as that extracted from the environment.

Table 15: Maximum value for Total Primary Energy (kWh/m²·year) for non-residential building according to climate zone

α	A	B	C	D	E
$165 + 9 \cdot C_{Fi}$	$155 + 9 \cdot C_{Fi}$	$150 + 9 \cdot C_{Fi}$	$140 + 9 \cdot C_{Fi}$	$130 + 9 \cdot C_{Fi}$	$120 + 9 \cdot C_{Fi}$

Where C_{Fi} corresponds to the mean internal heat loads

Annual Non-Renewable Primary Energy (kWh/m²): minimum non-renewable part of primary energy that must be supplied to the building.

Table 16: Maximum value for Non-Renewable Primary Energy (kWh/m²·year) for non-residential building according to climate zone

α	A	B	C	D	E
$70 + 8 \cdot C_{Fi}$	$55 + 8 \cdot C_{Fi}$	$50 + 8 \cdot C_{Fi}$	$35 + 8 \cdot C_{Fi}$	$20 + 8 \cdot C_{Fi}$	$10 + 8 \cdot C_{Fi}$

Where C_{Fi} corresponds to the mean internal heat loads

In essence, Annual Total Primary Energy tackles the building envelope performance, efficiency in HVAC, lighting and DHW of inhabited spaces excluding process loads and energy consumptions from unoccupied spaces, meanwhile Annual Non-Renewable Primary Energy offsets part of the Total Primary Energy with renewable energy. This means that in case of designing a building with less Primary Energy consumption than the Annual Total Primary Energy, the incorporation of electricity production to compensate any energy consumption would not be necessary.

Existing buildings with a complete renovation or a change in use of the building shall comply with the same requirements as the new buildings.

The parameters commented previously are the vectors used in Spain to ensure that, from now on, buildings become nearly Zero Energy Buildings (nZEB).

SAMPLE PROJECT

A sample project in which JG Ingenieros was responsible for the study of the building's energy consumption, is an office building located in Madrid (total area of 26.500 square meters, conditioned area of 11.500 square meters):

The heating and cooling loads of the building amount were about 1.300 kW and 700 kW respectively.

As shown in Figure 37, an external shading structure was planned in order to decrease energy consumption in summer (building energy demand kWh/m².year):

Table 17: Variation summary

	Heating demand	Cooling demand	Total demand	Variation
With external structure	19,36	31,15	50,51	-
Without external structure south	18,44	33,18	51,62	+2,20%
Without external structure northwest	19,34	31,93	51,27	+1,50%
Without external structure northeast	19,29	31,92	51,21	+1,39%
Without external structure south + southwest + northwest	18,36	34,16	52,52	+3,98%

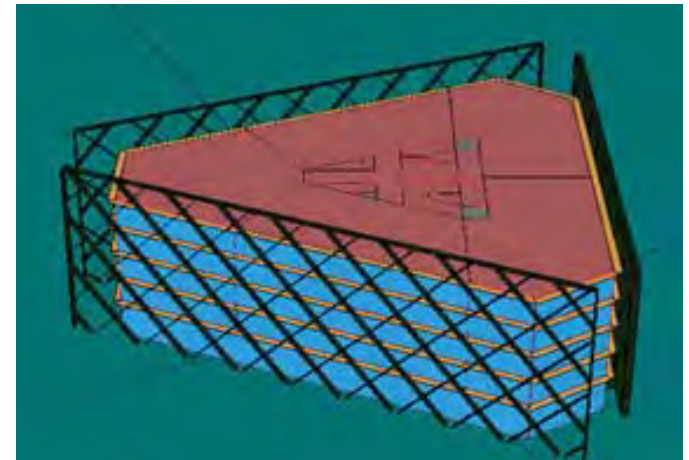

Figure 37: Office Project

As shown, this external structure leads to a decrease of a 4% of the building energy demand. In addition, a detailed analysis of the thermal bridges was carried out to increase the quality of the building envelope and prevent it from heat losses.

In order to achieve a high degree of efficiency, the building was simulated with three possible systems: air cooled chillers with boiler, water cooled chillers with boiler and Variable Refrigerant Volume systems. According to these alternatives, the amount of energy consumed for each alternative is as it follows:

Table 18: Consumed energy of different solutions

	End user Energy
Direct expansion	912.700 kWh/year
Boiler + water cooled chiller	1.182.230 kWh/year
Boiler + air cooled chiller	1.183.975 kWh/year

Although the VRV alternative turned out to be slightly more efficient, the promoter preferred a system in accordance with the rest of the buildings in its portfolio and consequently the project was drawn up with a water-cooled chiller and hot boiler. The energy efficiency lost in the chosen solution in reference to the VRV case was assumable.

The rest of elements of the HVAC were designed to minimize energy consumption, including a free cooling in the cooling tower, heat recovery and free cooling in the ventilation system and the use of very efficient fans. The lighting system for each space was carefully studied and designed to minimize the ratio of W/lux and try to make the most of daylight by means of light sensors.

The results of these simulations shown that the end use energy consumption decreases in a 23% with a reduction of a 13% of primary energy consumption and a reduction of a 11% of CO2 emissions using the most efficient of these systems.

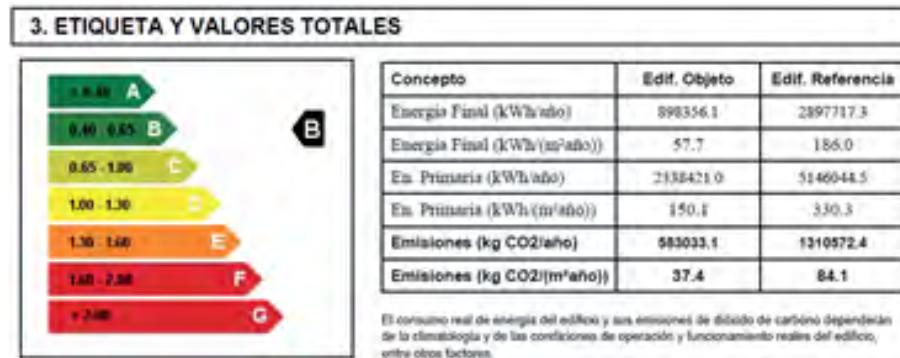
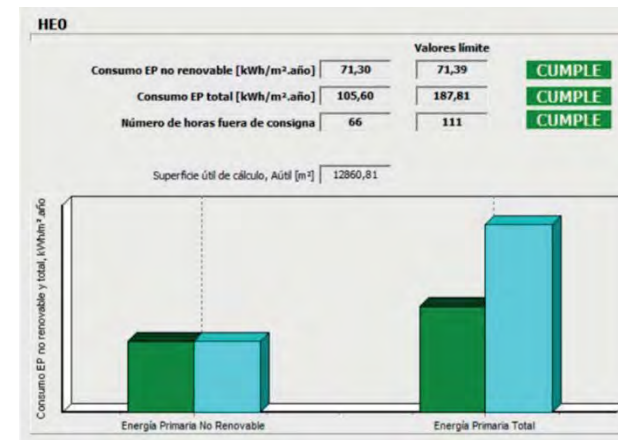

Figure 38: Previous local regulations Energy-Performance certificate of the building



Although the design of this building was made before the introduction of the new regulations in which nZEB was defined, JG Ingenieros have recently studied the possibility of turning this project into a nZEB Building. After this study, JG Ingenieros have reached the conclusion that the only change that has to be made is to add 635 m² of PV. With a production of only 200.000 kWh/year the building turns into a nZEB building:

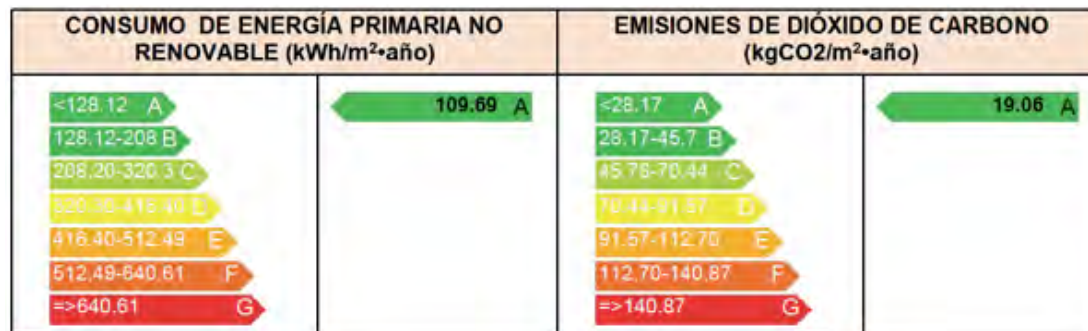

Figure 39: Current local regulations Energy-Performance certificate of the building

SWEDEN



REGULATIONS AND FIRST Q BEST PRACTICE

FIRST Q NETWORK | BUILDING PHYSICS GROUP

SWEDEN

COUNTRY REGULATION

The Swedish Government has since 2002 defined regulations regarding energy usage in newly built buildings, and since 2017 the energy regulations in Sweden are defined in accordance with the European Union introduction of “nearly Zero Energy Buildings” (nZEB). Progressively, the regulations have been updated and optimized. On September 1st, 2020, the new regulations (BFS 2020:4, BBR 29), and the final definition of nZEB in Sweden, were released. The overall Government goal is that the building regulations in a cost-effective way should contribute to technical neutral choices of sustainable heating systems and energy efficient buildings.

The regulations set minimum requirements for the energy performance of newly built buildings or when alterations are made on existing buildings. Energy performance is expressed as “Primary energy” [kWh/m²], which is a weighted energy performance indicator applied in normal use of a building during a standard year. The weighting factor differs depending on energy carrier and forms the basis for the calculation of energy performance considering Sweden's specific situation with an already very high proportion of renewable energy in several energy carriers (i.e. 0.6 for bio fuel and district cooling, 0.7 for district heating and 1.8 for electricity and fossil fuels). The energy for space heating is also multiplied with a geographical adjustment factor due to the different climate zones in Sweden. The energy requirement (divided into single-family houses, multi dwelling blocks and non-residential buildings) address space heating, cooling or air conditioning, hot tap water and the building's property electricity (HVAC, lighting etc.). The energy requirements are obliged to be verified during the planning stage of the building process.

Complementary regulations can also be found to minimize the energy performance for the building; Maximum requirements are set for the average heat transfer coefficient of the building envelope and the maximum installed electric input for heating. There are also recommendations for the energy efficiency of the specific fan power (SFP) for the HVAC system at the designed air flow rate.

The newly built buildings should verify the primary energy number by making an energy performance certification within two years, either by simulation or by measuring energy consumption. Most existing building must also have an energy declaration, no later than the time of sale. The overall purpose of energy performance certification of buildings is to be economical with energy and to promote sustainable development. The energy performance certification is a way to describe the energy performance of the building in accordance to the energy regulations in existing buildings and clarify how effective a building is from an energy point of view.

SAMPLE PROJECT

Tallbohov Electric Village is a housing project by Tornet AB in Järfälla, north of Stockholm, comprised of six towers with GFA of 14000m² and a capacity of 300 apartments. The project stands out for its ambitious goal of combining several energy sources with AI to optimise both heating and electricity systems, as well as actively encouraging residents into a more sustainable living.

Figure 40: Project vision

The buildings are connected to the district heating network, which is the most used heating system in Sweden's urban areas. A local facility then combines district heating with a geothermal heat pumps system, which together provide the building with heating and domestic hot water. The system is also connected with regular and hybrid solar panels on the inclined roofs that help cover part of electricity usage and recharging the boreholes, while surplus electricity being stored in batteries. A smaller hydrogen storage together with fuel cells has also been evaluated during the design phase of the project. An AI agent has also been developed in the project. The AI agent predicts the buildings' energy and power demand and helps residents to make sustainable choices. The AI agent also controls the buildings' energy systems to select the most sustainable energy supply.



Figure 40: Project vision

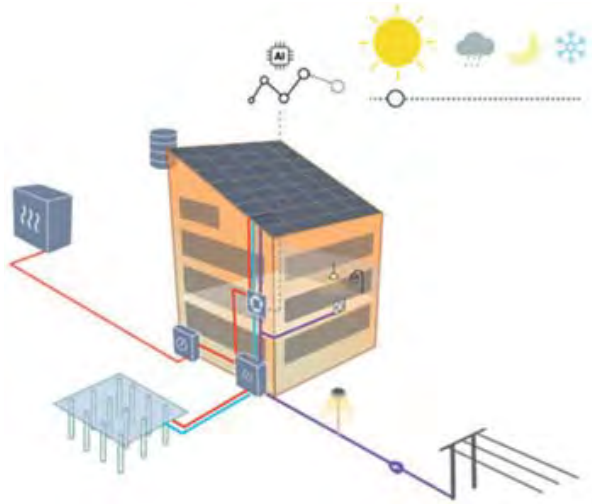

The preliminary energy simulation, illustrated in the picture below, shows that the buildings primary energy demand is 40,3 kWh/m², which is less than 49% of the national standard requirement as of 2019, (BFS 2019:2, BBR 28). This categorises the project in the Building energy class A, which moreover makes the project eligible for the highest level of state funding from the National Board of Housing, Building and Planning (Boverket).

Figure 41: Source: Tornet AB

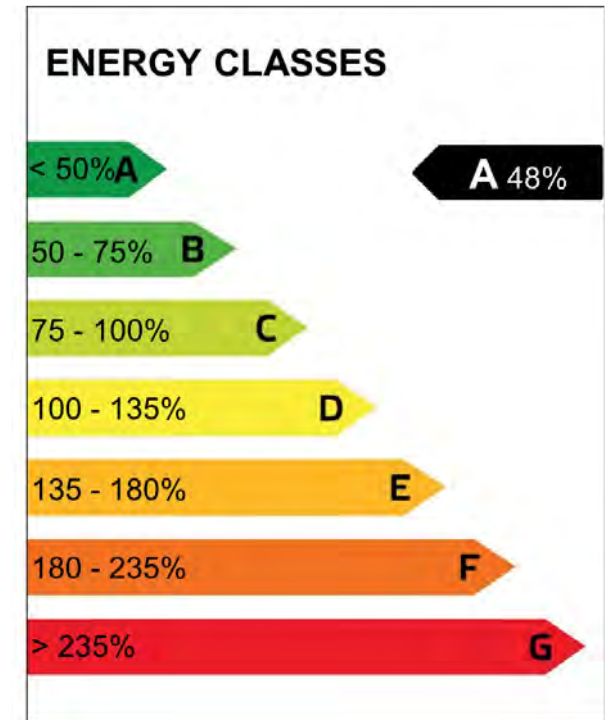
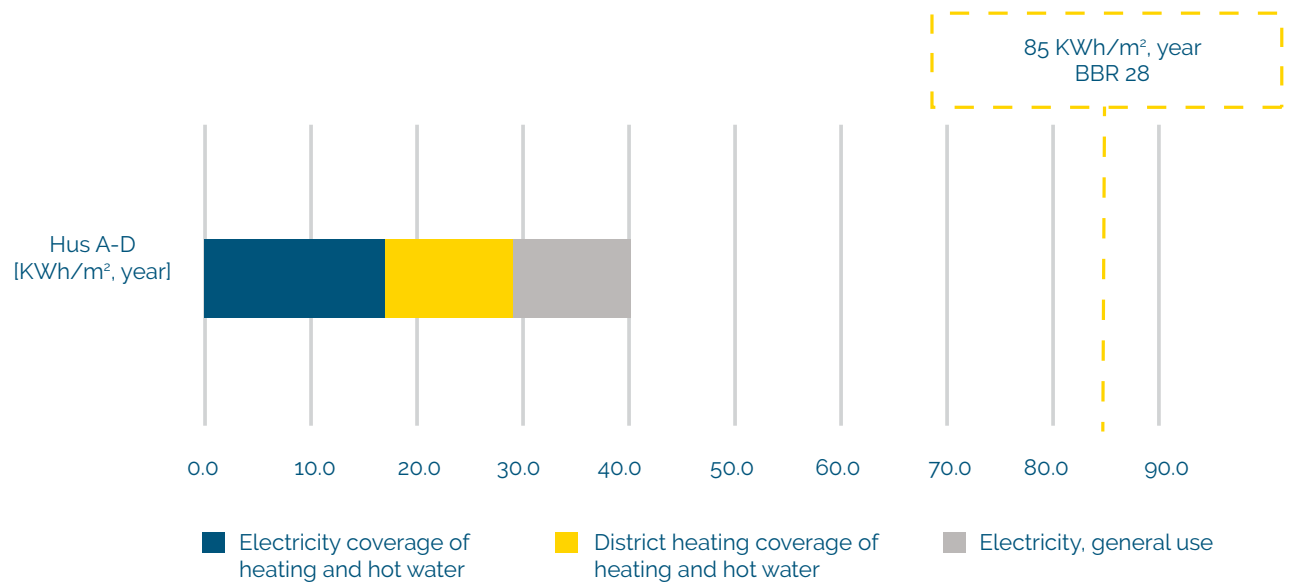

Figure 42: Calculated Primary energy and Energy classes based on the national standard requirement.

SWITZERLAND



REGULATIONS AND FIRST Q BEST PRACTICE

FIRST Q NETWORK | BUILDING PHYSICS GROUP

SWITZERLAND

COUNTRY REGULATION

In Switzerland, energy regulations in the building sector are defined by the individual cantons. They can use some model regulations for energy (so-called "Mustervorschriften der Kantone im Energiebereich, MuKE") to define specific measures. Due to the federal structure of our state, the implementation of the current version 2014 ("MuKE2014") is very heterogeneous: While the regulations are into force in some cantons since 2017, the implementation process is still going on in other cantons. In several cantons the implementation of MuKE2014 was rejected by referendum.

The cantonal energy ordinances define requirements for the thermal building envelope as well as for the energy consumption of HVAC, hot water and lighting in non-residential buildings. With the new energy regulations according to MuKE2014, the use of renewable energies has high priority. In new buildings, electricity production at the building (e.g. photovoltaic) is also prescribed.

Until now, there are no energy requirements in Switzerland, that comply with nZEB or comparable standards. However, most building categories can be certified according to the Minergie-P standard, that is derived from the German passive house standard and guarantees low energy consumption. There exists also the SNBS standard (Swiss variant of the DGNB) as an example of a comprehensive sustainability standard.

In order to achieve the climate protection targets, a CO₂ tax on fossil fuels such as heating oil or natural gas has been collected since 2008. Fuels for traffic are not affected by this so far. The tax rate is regularly reviewed and adjusted by the Federal Parliament.

At federal level, parts of the CO₂ tax and other funds are used to support energy-saving measures on the building envelope. For residential buildings, the applications for such subsidies require a so-called "Energieausweis der Kantone, GEAK". A GEAK is the swiss answer to the European standard EN 15217 "Energy performance of buildings – Methods for expressing energy performance and for the energy certification of buildings". For technical systems in buildings, the cantons and many other players have programmes for promoting renewable energies.

SAMPLE PROJECT

A project called RIVA consist of 4 residential buildings with a total of 86 flats (total GFA of 14,056 m²). It was built on the site of the former children's hospital and is considered the first large MINERGIE-P-ECO project in Basel.

Already during the competition, in which Waldhauser + Hermann AG was also involved in 2009, sustainability was an important issue. For the realisation of the project from 2010 on, our services included the energy concept, the planning of heating, ventilation and the Minergie-P certification. The project was completed in 2014.

The buildings are heated with ground water heat pumps. About 1/3 of the domestic hot water is produced by solar thermal systems, the remaining part is supplied by ground water heat pumps. During the warm season, the buildings can be gently cooled by using the ground water and the floor heating system.



Figure 43: Project RIVA Basel

For each of the 4 residential buildings the Minergie-P certification was executed separately. The figure below exemplifies the Minergie-P application for building D: In a first step, the insulation standard of the building envelope is evaluated by calculating the standardised heat demand (so-called "Primäranforderung an Gebäudehülle"). The heat demand may not exceed 60% of the limit value according to the SIA standard. An energetic evaluation is then carried out by determining the energy source mix, taking into account efficiency and weighting factors (so-called "Grenzwert Minergie-P"). For example, electricity is weighted with a factor 2 considering the production mix. However, this factor is a political compromise and only partially considers the primary energy factor.

Building D fulfils both criteria "Primäranforderung an Gebäudehülle" and "Grenzwert Minergie-P" of the Minergie-P standard.

Projekt: **WAB RIVA Basel - altes Kinderspital, Neue D** 28.2.2011

Altenheimstrasse 8

Gebäudehülle, Lüftung und Grenzwert:		1	2	3	4	Erlaubnis	
N1	Klimatisierung + Heizungen	Bayer-Berlingen					
N2							
N3	SBF	m ²	4363			4363	
N4	Qh MP mit Standardwert	kWh/m ²	13.1			13.1	
N5	Qh Wärmehilf Warmwasser	kWh/m ²	20.8			20.8	
N6	Therm. Ausstrahlungsleistung	kWh/m ²	0.33			0.33	
N7	Wärmehilf Qh,eff	kWh/m ²	9.3			9.3	
N8	Lüftungsmenge	Klimatisierung					
N9	Wärmehilf Lüftung	kWh/m ²	3.12			3.12	
N10	Summ. Wärmehilf / Lüftung	kWh/m ²	3.3			3.3	
N11	Grenzwert	kWh/m ²	30.0			30.0	
N12							
N13							
N14	Maßgebender Grenzwert	kWh/m ²	30.0			30.0	

Wärmeerzeugung:	n	Gewicht	Beitragung	gewichteter Endenergiefaktor	Grenzwert	
Heizung + Warmwasser	über 20	kg	Wärme	Wärme kWh/m ²	kWh/m ²	
N15	Grundwasser-WP, mit. Heizung	2.1	2	100.0%	4.7	0.3
N16	Grundwasser-WP, mit. Wärme	2.1	2		88.2%	14.2
N17	Solaranlage therm. Warmwasser				11.8%	6.8
N18						
N19						
N20	Wärmehilf Lüftung		2		6.2	
N21	Summ. Wärmehilf		2		6.5	
N22	Total			100%	100%	27.2

Erfüllung der Anforderungen:	Anforderung	Berechneter Wert	Erfüllt?	
N23	Primäranforderung an Gebäudehülle	13.1 kWh/m ²	13.1 kWh/m ²	Ja
N24	Grenzwert MINERGIE - P	30.0 kWh/m ²	30.0 kWh/m ²	Ja
N25	Thermischer Komfort im Sommer			Ja
N26				

Zusatzanforderungen:	erfüllt?	z)	Nachweis beizubringen (Zusatzanforderungen)
N27	Heizung	Ja	
N28			
N29			
N30			
N31			
N32			
N33	Lüftungsmenge der Gebäudehülle	Ja	Lüftungsmenge - Protokoll mit Prüfbericht

Beilagen gem. "Checkliste für Antragsteller" siehe:

www.minergie.ch

N34	<input type="checkbox"/>	<input type="checkbox"/>
N35	<input type="checkbox"/>	<input type="checkbox"/>
N36	<input type="checkbox"/>	<input type="checkbox"/>
N37	<input type="checkbox"/>	<input type="checkbox"/>
N38	<input type="checkbox"/>	<input type="checkbox"/>
N39	<input type="checkbox"/>	<input type="checkbox"/>
N40	<input type="checkbox"/>	<input type="checkbox"/>
N41	<input type="checkbox"/>	<input type="checkbox"/>

542 Ort, Datum: **Basel, 28.2.2011** Unterschrift Antragsteller: _____

543 Ort, Datum: **München, 28.2.2011** Unterschrift Fachperson 1 und 2: _____

Minergie-P Antrag Form 01 Fachwerk / 28.05.2011, 09:22 Minergie-P Schweiz

Figure 44: Minergie-P certificate of RIVA building D

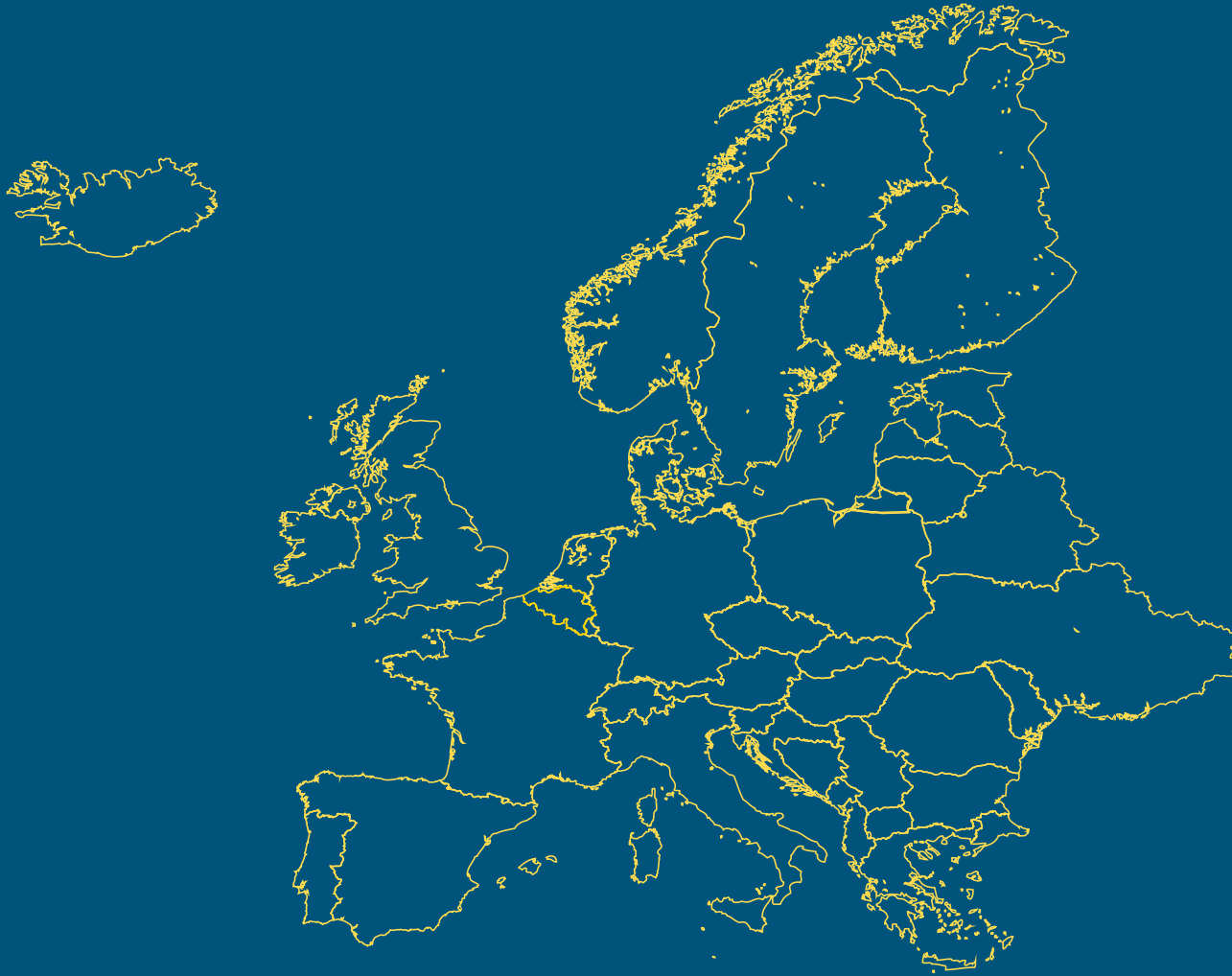

REGULATIONS AND FIRST Q BEST PRACTICE

FIRST Q NETWORK | BUILDING PHYSICS GROUP

SUMMARY

OVERVIEW

A compact overview of the sample projects is listed in the Table 19 below. Due to the diversity of building energy regulations, and definitions of reference buildings and nZEBs, as well as varying climates, the primary energy demands of heating, cooling, lighting and so on cannot be compared directly. Nonetheless, a parallel, which will help understand the general idea and compare requirements for a nZEB in each of the mentioned countries, can be drawn. The building energy class in the projects is defined based on two parameters; primary energy demand and CO₂ emissions, which can be evaluated and compared throughout the countries.

Table 19: Overview of sample projects

Location	Building type	GFA [m ²]	Supply System	Specific primary energy consumption* [kWh/m ² ·year]	Specific CO ₂ emissions [kg/m ² ·year]	Building energy class
Belgium	Office	2600	3 Air/water Heat pumps	84,17	21,51	(E40) Flemish region
Finland	Mixed use, commercial/retail, office	N/A	?	80,00/95,00	N/A	N/A
France	Office	24000	District heating and geothermal heat	47,80	N/A	A
Germany	Office	10700	Groundwater/water heat pump and HVAC Chiller	43,00	5,74	75% EnEV
Ireland	Mixed use, commercial/retail	18600	4-pipe air source heat pump chiller	83,00	16,00	A3
Italy	Office	45000	Reversible heat pump	127,44	37,73	A3
Lithuania	Office	22493	Air heat pump and district heating	136,9	19,23	A++
Portugal	Office	15690	2 water cooled heat pump chillers and 1 air cooled heat pump chiller	145,40	20,81	A
Spain	Office	26500	water-cooled chiller and hot boiler	109,69	19,06	A
Sweden	Residential	14000	District heating combined with geothermal heat pumps and solar panels	40,30	4,3	A
Switzerland	Residential	14056	Groundwater/water heat pump and solar thermal collector	44,50	7,30	A

* kWh/m² conditioned area

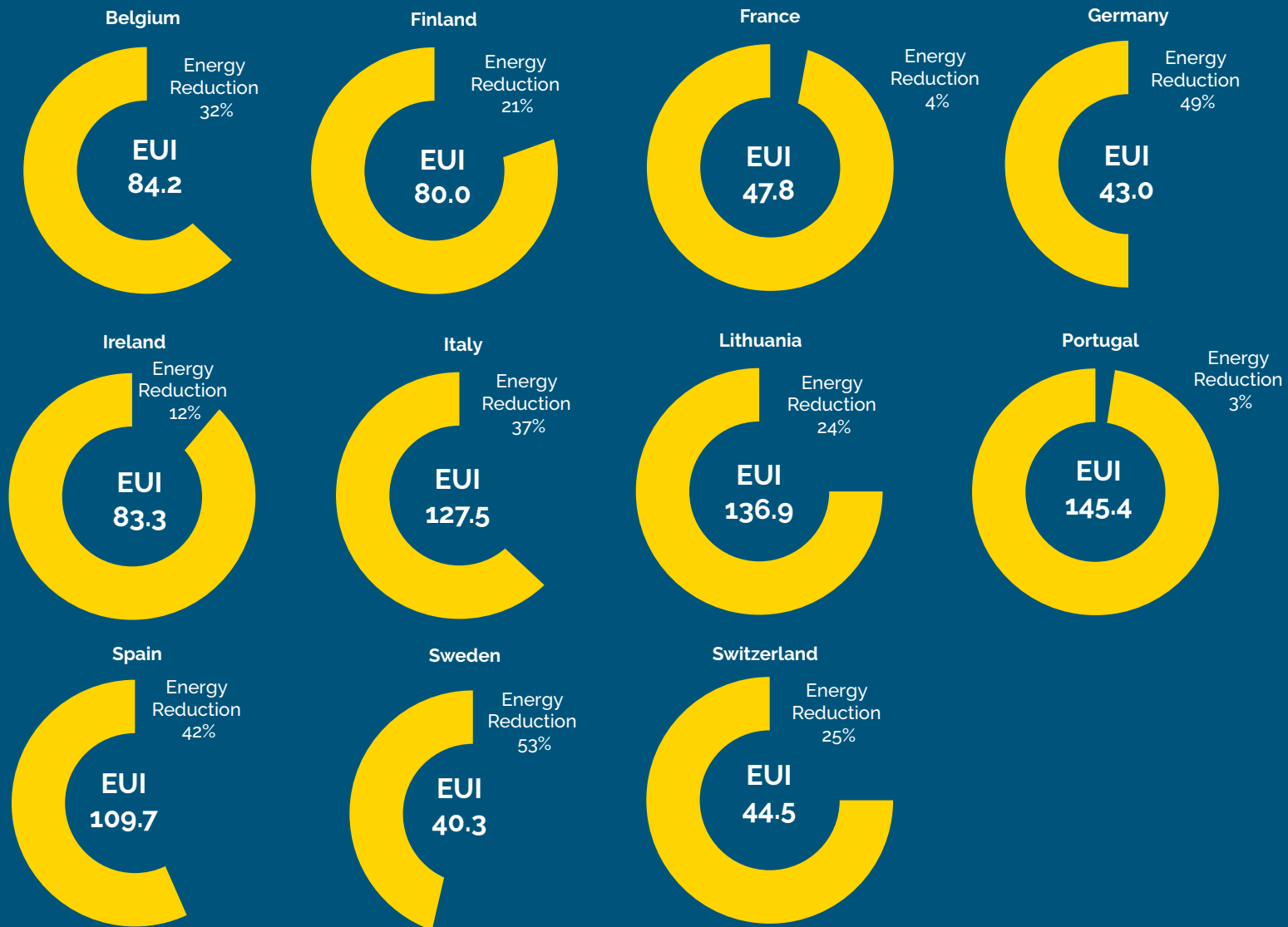

Figure 45: EUI and energy reduction – Project overview

Due to the different types of projects in various climates, different calculation methods for primary energy consumption and CO2 emissions of electricity, the following graphs cannot be used to draw any direct comparison between countries considered in this paper. Instead, they give us an overview of the sample projects and serve as a base for the conclusion and outlook.

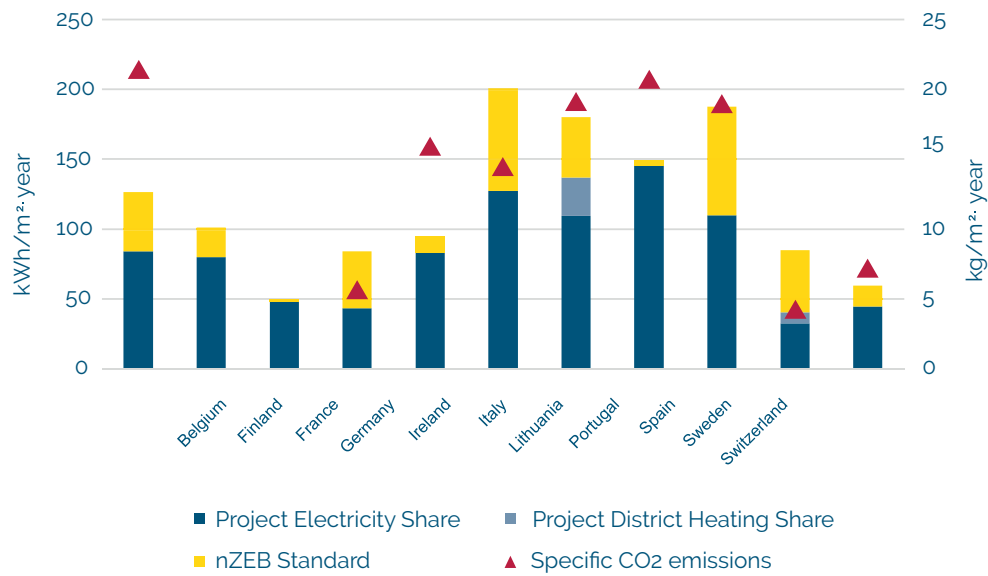

Figure 46: Specific CO2 emissions, Specific primary energy consumption of sample projects with reference values

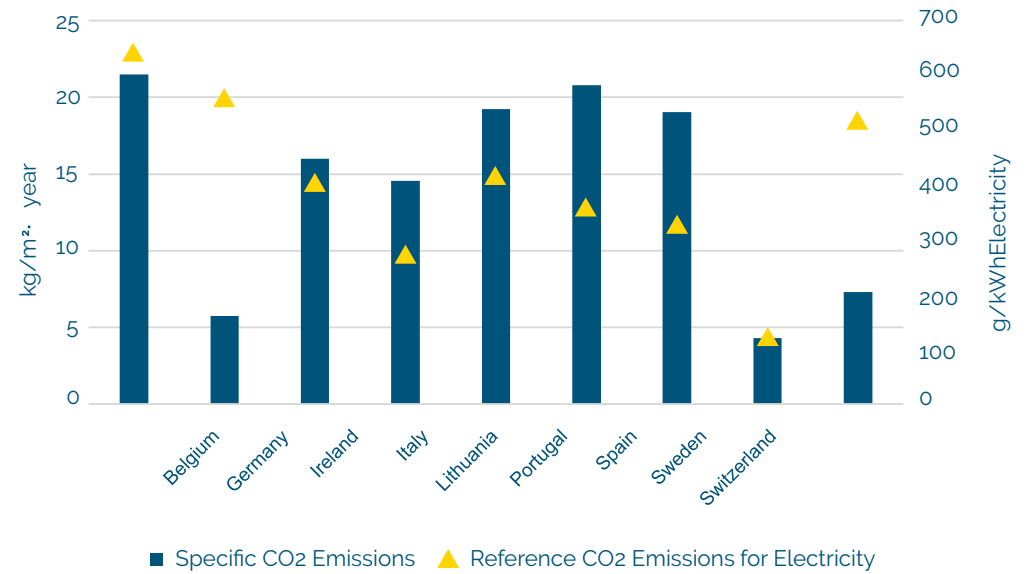

Figure 47: Comparison of specific CO2 emissions of the sample project and the specific values for electricity

CONCLUSION AND OUTLOOK

Although all regulations from European countries start within the same framework, there are a lot of differences due to historical and geopolitical reasons, both for metrics and calculation methodology. Common parameters and concept are the same (primary energy as main indicator, renewables promotion, CO₂ emission reduction as the final goal), but approaches are unique for each country. Although expected to be straightforward, nZEBs definitions vary, since all countries identify specific and unique parameters, sometimes not directly linked to primary energy minimization.

However, as shown within sample projects, there are common factors. In order to ensure overall energy performance, all the project considered first passive strategies, then, only after an engineered optimization, efficient active systems. The following passive and active solutions were implemented in the building design to maximise the energy performance of the building:

Passive Solutions:

- High quality of the building envelope (including coated windows and blinds)
- Passive solar design - optimising internal gains through early phase thermal simulation
- Optimising the thermal storage effect of the building
- Highly efficient lighting solutions

Active Solutions:

- Integrating renewable energy sources through renewable energy systems for heating and cooling purposes
- Using waste heat recovery solutions in HVAC systems
- Implementing energy storage technologies (thermal and electrical) for load management purposes (peak shaving, load shifting scenarios)
- Integrating smart energy control systems: predictive and interactive control models, AI optimisation, energy monitoring

Combining these passive and active measures through innovative renewable energy concepts and solutions confronts the challenges of a nZEB or a Carbon Neutral Building.

With the exception of Sweden, the regulations to date have focused on a 'design for compliance' approach i.e. the predicted energy use of buildings is modelled at design stage. In Sweden, the use of actual energy consumption as the basis of buildings' energy performance assessment has been important for achieving better energy efficiency for building. For most countries, the in-use or operational energy is not monitored after the building is handed over. This is creating a performance gap between the virtual reality of computer modelling and the reality of actual performance. Adopting a 'design for performance' approach which includes measurement of actual building performance will be required if this performance gap is to be bridged.

Another important aspect in the drive towards net zero energy buildings is the need for collaboration with the final tenants or occupants. Monitoring of the energy used by small power / plug loads will require buy-in from the tenants as part of lease agreements. The sample project from Sweden illustrates how an AI agent has been developed to assist the occupant in choosing the most sustainable outcomes.

To tackle the high energy performance considered by EPBD for nZEBs, it will be crucial to define numeric thresholds and ranges, based on climate zones, for end energy demand of HVAC systems, renewable share and CO2 Emissions and to consider them in the early stages of planning. In the future design and planning of buildings, matters like embodied energy, aerosol infection transmission rate, resilience to climate change, flexibility to match different uses and occupation density in an easy way will be of immense importance and should start being considered as of now. By tackling these new challenges, we will be giving building owners and users a more complete idea about how the most valuable buildings can be delivered to the real estate market.

The FirstQ network hereby demonstrated its capabilities and solutions that go into planning nZEBs on various locations and climates. Offices of the FirstQ network will continue to strive for greater success with the pledge to plan more Zero or Plus Energy Buildings and Carbon Neutral Buildings in the future.

LIST OF ABBREVIATIONS

AHU – Air Handling Unit
AI – Artificial Intelligence
BMS – Building Management System
CTR – Construction Technical Regulation
EPBD – Energy Performance of Buildings Directive
EUI – Energy Use Intensity
GFA – Gross Floor Area
MEP – Mechanical, Electrical and Plumbing
SHGC – Solar Heat Gain Coefficient
VRV – Variant Refrigerant Volume

LIST OF TABLES

Table 1: nZEB Levels Flemish Region
Table 2: nZEB Level Walloon region
Table 3: Building Physics
Table 4: Primary energy consumption (E-value) limit for different building types
Table 5: Primary energy factors
Table 6: Fabric U-Values
Table 7: HVAC Summary
Table 8: Project overview
Table 9: Building envelope
Table 10: Building glazing
Table 11: Chillers efficiency
Table 12: AHU and pumps efficiency
Table 13: Lighting requirements
Table 14: Energy indicators
Table 15: Maximum value for Total Primary Energy (kWh/m²·year) for non-residential building according to climate zone
Table 16: Maximum value for Non-Renewable Primary Energy (kWh/m²·year) for non-residential building according to climate zone
Table 17: Variation summary
Table 18: Consumed energy of different solutions
Table 19: Overview of sample projects

LIST OF FIGURES

- Figure 1:** Map of the Köppen-Geiger climate classification
- Figure 2:** Possible system boundaries for a building [Source: EN ISO 52000-1: 2017]
- Figure 3:** BEN-label Flemish region
- Figure 4:** Stadsbader office building
- Figure 5:** Hydraulic scheme heating and cooling
- Figure 6:** Energy performance certificate
- Figure 7:** Finnish policy mix for building energy efficiency in 2017
- Figure 8:** Example of Finnish Building Energy Certificate
- Figure 9:** Energy performance requirements for building renovation
- Figure 10:** Photo of Tripla [Source: <https://www.yit.fi/en/homes/apartments-for-sale/helsinki/pasila/tripla>]
- Figure 11:** Calculated energy consumptions
- Figure 12:** Limit of maximum energy consumption of new residential buildings
- Figure 13:** RE 2020 Logo
- Figure 14:** Project Java rendering
- Figure 15:** Thermal slab solution scheme
- Figure 16:** Project JAVA
- Figure 17:** Primary energy consumption
- Figure 18:** Project Kaltenbornweg [Source: format-architektur.de]
- Figure 19:** Energy supply concept of the building
- Figure 20:** Annual CO₂-Emission of the investigated energy supply variants
- Figure 21:** Annual operation costs of the investigated energy supply variants
- Figure 22:** Energy-Performance certificate of the building
- Figure 23:** Mixed Use Commercial Project Smithfield, Co. Dublin
- Figure 24:** Energy Hierarchy
- Figure 25:** Provisional Building Energy Rating (BER)
- Figure 26:** BRIRL Output Document
- Figure 27:** Project rendering by Skidmore, Owings & Merrill
- Figure 29:** Early phase energy modelling
- Figure 28:** Axonometric view of the project
- Figure 30:** Rendering of the building B façade
- Figure 31:** Rendering of the building A facades
- Figure 32:** HVAC systems BIM design
- Figure 33:** Energy certification for one of the building blocks
- Figure 34:** Office building "FLOW" in Vilnius
- Figure 35:** Energy-Performance certificate of the building
- Figure 36:** Project Metropolis
- Figure 37:** Office Project
- Figure 38:** Previous local regulations Energy-Performance certificate of the building
- Figure 39:** Current local regulations Energy-Performance certificate of the building
- Figure 40:** Project vision
- Figure 41:** Source: Tornet AB
- Figure 42:** Calculated Primary energy and Energy classes based on the national standard requirement.
- Figure 43:** Project RIVA Basel
- Figure 44:** Minerie-P certificate of RIVA building D
- Figure 45:** EUI and energy reduction – Project overview
- Figure 46:** Specific CO₂ emissions, Specific primary energy consumption of sample projects with reference values
- Figure 47:** Comparison of specific CO₂ emissions of the sample project and the specific values for electricity

**Belgium**

Igenium n.V.
Nieuwe St-Annadreef 23
B-8200 Brugge
Belgium
+32 50 40 45 30
info@ingenium.be

**Finland**

Granlund Oy
Malminkaari 21, P.O. Box 59
FI-00701 Helsinki
Finland
+358 10 7592 000

**France**

Barbanel – Siège social
Green Square – Bât. C
8 avenue Louis Pasteur
92227 BAGNEUX Cedex
+33 1 82 00 14 40
contact@barbanel.fr

**Germany**

ZWP Ingenieur-AG
An der Münze 12-18
50688 Köln
Germany
+49 221 973182-0
info@zwp.de

**Ireland**

Ethos Engineering
Penthouse Suite
Apex Business Centre
Blackthorn Road,
D18 DH76 Sandyford
Ireland
+353 1 293 2220
info@ethoseng.ie

**Manens-Tifs****Italy**

Manens-Tifs s.p.a.WP
Corso Stati Uniti n. 56
35127 Padova
Italy
+39 49 8705110
info@manens-tifs.it

**Lithuania**

UAB "Mepco"
Konstitucijos pr. 23
08105 Vilnius
Lithuania
+370 5 2440155
projects@mepco.lt

**Portugal**

LMSA - Engenharia de Edifícios
Av. Eng. Arantes e Oliveira, 1, S/LB
1900-221 Lisboa
Portugal
+351 218 920 900
info@lmsa.pt

**Spain**

JG INGENIEROS
Comte d'Urgell 240, 4ª planta
08036 Barcelona
Spain
+34 936004900
jg@jgingenieros.es

**Sweden**

Bengt Dahlgren AB
Krokslätts Fabriker 52
431 37 Mölndal
Sweden
+46 31 7202500
reception.goteborg@
bengtdahlgren.se

**Switzerland**

Waldhauser + Hermann AG
Ingenieurbüro USIC/SIA
Florenzstrasse 1d
4142 Münchenstein 1
Switzerland
+41 61 3369494
mail@waldhauser-hermann.ch

**UK**

London (Headquarters)
40 Gracechurch Street
London
EC3V 0BT
UK
+44 (0) 20 7618 4800



**FIRST Q NETWORK | BUILDING PHYSICS GROUP
TWO THOUSAND AND TWENTY ONE | WHITE PAPER SERIES**